

# VGR · Screw-Terminal · 6000 h/105 °C

High Ripple Current · Bottom cooling design · Low ESR

## > Specifications · Spezifikationen

Items	Characteristics
Temperature range	-40°C ~ + 105°C
Capacitance tolerance (at 20°C)	Standard +/- 20%, -10/+30% on request
Surge voltage / Ripple voltage	Repetitive max. 30 sec per 6 Minutes / ≤ 70V
Leakage current max. I <sub>L</sub> (20°C, 5 min)	0.01 · C · V <sub>r</sub> [μA] or 5 mA, which is smaller.
Useful life	6000 hours at 105°C
Field failure rate	0.5 FIT = 0.5 · 10 <sup>-9</sup> Failures/hour
Reference standards	IEC 60384-4, JIS C 5101-4
Vibration	0.75mm, 10...55Hz, 10g, 3x2h
Outer materials	UL94-V0/UL224-VW1 certified (cap/sleeve)
Sleeve withstanding voltage	4000 Vac/1min between terminals bundled and plate*
Product Compliance	RoHS, REACH, Conflict Minerals a.o. – refer to p. 14–15

\* Typical value



## > Shape designation · Formbezeichnung

- additional information on p. 12–13 · Zusatzinformationen auf S. 12–13
- mounting accessories from p. 219 · Montagezubehör ab S. 219

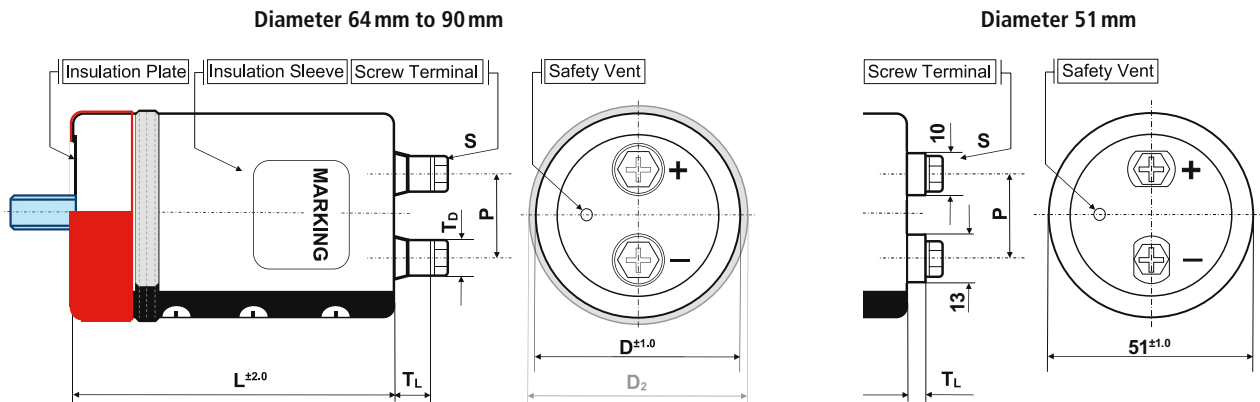

Shape code Features	B Bolt	I/Y double sleeve for 2/3 points metal Bracket	N + suffix WC blank bottom + seating ring	N standard
outer insulation sleeve	•	•	•	•
insulation plate	•	•		•
stud bolt	•			
bottom double sleeve		•		
integrated seating ring			•	

diameter code	ØD	available shape	P	S	T <sub>L</sub>	T <sub>D</sub>	Cap material
C	51	B, N, I, Y	22.0	M5x10	4.5	13/10	PH
D	64	B, N, I, Y	28.6	M5x10	8.0	11	PH
E	77	B, N, I, Y, WC	31.5	M6x12	9.0	12	PH
F	90	B, N, I, Y, WC	31.5	M6x12	8.0	12	PH

Size in mm

> Product Code · Bestellbezeichnung

**Example:** Series VGR · 12000 µF +/- 20 % · 400 V · D=90 mm · L=190 mm with Y-Bracket

**VGR**    **2G**    **123**    **Y**    **F**    **190**

Series name    Capacitance code    Shape code    Diameter code    Capacitance tolerance    Specific features

Rated voltage code

Code	Voltage	Code	Voltage
2V	350	2W	450
2G	400	2H	500

∅ : ± 20 %  
Q : -10 % ~ +30 %

Case length code – length in mm (3 digits)

Rated Voltage Code (Surge Voltage) V <sub>r</sub> [V DC]	Capacitance C <sub>r</sub> [µF]	Ripple Current at 105°C/120Hz I <sub>r</sub> [A RMS]	Ripple Current at 40°C/120Hz [A RMS]	ESR (typ) at 20°C/100Hz [mΩ]	Z <sub>max</sub> at 20°C/10kHz [mΩ]	ESL (typ) [nH]	Dissipation Factor at 20°C/120Hz Tan δ	DxL [mm]	Product Code # = variable value, see fixing code in the product code
<b>350 VDC</b> Code: 2V  Surge Voltage 400 VDC	1 800	9.1	21.0	30	31	17	0.20	51x96	VGR2V182#C096
	2 200	9.8	22.6	25	26	17	0.20	51x96	VGR2V222#C096
	2 700	11.0	25.3	20	21	17	0.20	51x109	VGR2V272#C109
	3 300	12.2	28.1	16	19	17	0.20	51x125	VGR2V332#C125
		15.1	34.7	16	19	18	0.20	64x107	VGR2V332#D107
	3 900	16.5	38.0	14	16	18	0.20	64x107	VGR2V392#D107
	4 700	18.0	42.5	11	13	18	0.20	64x107	VGR2V472#D107
		20.6	47.4	11	13	20	0.20	77x108	VGR2V472#E108
	5 600	20.1	46.3	10	11	18	0.20	64x147	VGR2V562#D147
		22.8	52.5	10	11	20	0.20	77x108	VGR2V562#E108
	6 800	22.3	51.3	8	10	18	0.20	64x164	VGR2V682#D164
		25.1	57.8	8	10	20	0.20	77x124	VGR2V682#E124
	8 200	28.6	65.8	8	10	20	0.20	90x110	VGR2V682#F110
		24.8	57.1	7	8	18	0.20	64x187	VGR2V822#D187
		27.6	63.5	7	8	20	0.20	77x148	VGR2V822#E148
	10 000	31.3	72.0	7	8	20	0.20	90x110	VGR2V822#F110
		30.6	70.4	5	7	20	0.20	77x165	VGR2V103#E165
		34.3	78.9	5	7	20	0.20	90x150	VGR2V103#F150
12 000	33.8	77.8	5	5	20	0.20	77x188	VGR2V123#E188	
	37.6	86.5	5	5	20	0.20	90x150	VGR2V123#F150	
	41.6	95.7	4	5	20	0.20	90x167	VGR2V153#F167	
18 000	45.3	104.2	3	4	20	0.20	90x190	VGR2V183#F190	
22 000	48.3	111.1*	3	3	20	0.20	90x268	VGR2V223#F268	
27 000	50.0	115.0*	3	4	20	0.20	90x268	VGR2V273#F268	
<b>400 VDC</b> Code: 2G  Surge Voltage 450 VDC	1 500	8.4	19.4	35	38	17	0.20	51x96	VGR2G152#C096
	1 800	9.1	21.0	30	32	17	0.20	51x96	VGR2G182#C096
	2 200	10.2	23.5	24	26	17	0.20	51x109	VGR2G222#C109
	2 700	11.4	26.3	20	22	17	0.20	51x125	VGR2G272#C125
		13.6	31.3	20	22	18	0.20	64x107	VGR2G272#D107
	3 300	15.2	35.0	16	18	18	0.20	64x107	VGR2G332#D107
	3 900	16.7	38.5	14	16	18	0.20	64x123	VGR2G392#D123
		16.5	38.0	14	16	18	0.20	64x147	VGR2G392#D147
		18.8	43.2	14	16	20	0.20	77x108	VGR2G392#E108

Additional designs on request · Weitere Designs auf Anfrage

# VGR · Screw-Terminal · 6000 h/105 °C

Rated VoltageCode (Surge Voltage) $V_r$ [V DC]	Capacitance $C_r$ [µF]	Ripple Current at 105°C/120Hz $I_r$ [A RMS]	Ripple Current at 40°C/120Hz [A RMS]	ESR (typ) at 20°C/100Hz [mΩ]	Zmax at 20°C/10kHz [mΩ]	ESL (typ) [nH]	Dissipation Factor at 20°C/120Hz Tan δ	DxL [mm]	Product Code  # = variable value, see fixing code in the product code
<b>400 VDC</b> Code: 2G  Surge Voltage 450 VDC	<b>4 700</b>	18.4	42.4	11	13	18	0.20	64x147	VGR2G472#D147
		20.9	48.1	11	13	20	0.20	77x108	VGR2G472#E108
	<b>5 600</b>	20.2	46.5	10	11	18	0.20	64x164	VGR2G562#D164
		23.1	53.1	10	11	20	0.20	77x124	VGR2G562#E124
		26.0	59.8	10	11	20	0.20	90x110	VGR2G562#F110
	<b>6 800</b>	22.6	52.0	8	10	18	0.20	64x187	VGR2G682#D187
		25.1	57.8	8	10	20	0.20	77x148	VGR2G682#E148
		28.6	65.8	8	10	20	0.20	90x93	VGR2G682#F093
	<b>8 200</b>	27.4	63.0	7	8	20	0.20	77x148	VGR2G822#E148
		31.0	71.3	7	8	20	0.20	90x150	VGR2G822#F150
	<b>10 000</b>	30.9	71.1	5	7	20	0.20	77x188	VGR2G103#E188
		34.3	78.9	5	7	20	0.20	90x150	VGR2G103#F150
	<b>12 000</b>	37.2	85.6	5	5	20	0.20	90x167	VGR2G123#F167
		41.4	95.2	4	5	20	0.20	90x190	VGR2G153#F190
	<b>15 000</b>	40.4	92.9	4	5	20	0.20	90x230	VGR2G153#F230
		43.7	100.5*	3	4	20	0.20	90x268	VGR2G183#F268
<b>22 000</b>	45.1	103.8*	2	3	20	0.20	90x268	VGR2G223#F268	
<b>450 VDC</b> Code: 2W  Surge Voltage 500 VDC	<b>1 200</b>	7.9	18.2	44	47	17	0.20	51x96	VGR2W122#C096
	<b>1 500</b>	8.7	20.1	36	39	17	0.20	51x96	VGR2W152#C096
	<b>1 800</b>	9.7	22.4	30	33	17	0.20	51x109	VGR2W182#C109
		10.1	23.3	30	33	17	0.20	51x125	VGR2W182#C125
	<b>2 200</b>	10.9	25.1	24	27	17	0.20	51x125	VGR2W222#C125
		12.6	29.0	24	27	18	0.20	64x107	VGR2W222#D107
	<b>2 700</b>	14.1	32.5	20	22	18	0.20	64x107	VGR2W272#D107
		16.1	37.0	20	22	20	0.20	77x108	VGR2W272#E108
	<b>3 300</b>	15.8	36.4	16	18	18	0.20	64x123	VGR2W332#D123
		18.0	41.4	16	18	20	0.20	77x108	VGR2W332#E108
	<b>3 900</b>	17.2	39.6	14	16	18	0.20	64x147	VGR2W392#D147
		19.6	45.1	14	16	20	0.20	77x124	VGR2W392#E124
		22.3	51.3	14	16	20	0.20	90x110	VGR2W392#F110
	<b>4 700</b>	19.3	43.7	11	13	18	0.20	64x164	VGR2W472#D164
		21.6	49.7	11	13	20	0.20	77x139	VGR2W472#E139
		24.4	56.2	11	13	20	0.20	90x110	VGR2W472#F110
	<b>5 600</b>	21.1	48.6	10	11	18	0.20	64x187	VGR2W562#D187
		23.0	52.9	10	11	20	0.20	77x139	VGR2W562#E139
		26.5	61.0	10	11	20	0.20	90x126	VGR2W562#F126
	<b>6 800</b>	25.9	59.6	8	10	20	0.20	77x165	VGR2W682#E165
		29.0	66.7	8	10	20	0.20	90x150	VGR2W682#F150
	<b>8 200</b>	28.7	66.1	7	8	20	0.20	77x188	VGR2W822#E188
		31.8	73.1	7	8	20	0.20	90x150	VGR2W822#F150
	<b>10 000</b>	31.6	72.7	6	7	20	0.20	90x150	VGR2W103#F150
<b>12 000</b>	38.1	87.6	5	7	20	0.20	90x190	VGR2W123#F190	
<b>15 000</b>	41.0	94.3	4	5	20	0.20	90x268	VGR2W153#F268	
<b>18 000</b>	41.9	96.4	3	4	20	0.20	90x268	VGR2W183#F268	

Additional designs on request · Weitere Designs auf Anfrage

Rated VoltageCode (Surge Voltage) $V_r$ [V DC]	Capacitance $C_r$ [ $\mu$ F]	Ripple Current at 105°C/120Hz $I_r$ [A RMS]	Ripple Current at 40°C/120Hz [A RMS]	ESR (typ) at 20°C/100Hz [m $\Omega$ ]	Zmax at 20°C/10kHz [m $\Omega$ ]	ESL (typ) [nH]	Dissipation Factor at 20°C/120Hz Tan $\delta$	DxL [mm]	Product Code  # = variable value, see fixing code in the product code
<b>500 VDC</b> Code: 2H  Surge Voltage 550 VDC	680	4.6	10.6	85	90	17	0.20	51x96	VGR2H681#C096
	820	5.2	12.0	70	74	17	0.20	51x109	VGR2H821#C109
	1 000	5.7	13.2	58	62	17	0.20	51x109	VGR2H102#C109
	1 200	6.4	14.8	48	52	17	0.20	51x125	VGR2H122#C125
	1 500	8.4	19.3	38	41	18	0.20	64x107	VGR2H152#D107
	1 800	9.3	21.4	32	36	18	0.20	64x107	VGR2H182#D107
		10.3	23.7	26	30	18	0.20	64x123	VGR2H222#D123
	2 200	11.7	26.9	26	30	20	0.20	77x108	VGR2H222#E108
		11.5	26.5	22	26	18	0.20	64x147	VGR2H272#D147
	2 700	13.1	30.2	22	26	20	0.20	77x108	VGR2H272#E108
		13.0	29.9	18	21	18	0.20	64x187	VGR2H332#D187
	3 300	14.5	33.4	18	21	20	0.20	77x124	VGR2H332#E124
		16.5	38.0	18	21	20	0.20	90x110	VGR2H332#F110
	3 900	15.8	36.4	15	18	20	0.20	77x148	VGR2H392#E148
		17.9	41.2	15	18	20	0.20	90x110	VGR2H392#F110
	4 700	17.3	39.8	13	15	20	0.20	77x165	VGR2H472#E165
		19.6	45.1	13	15	20	0.20	90x126	VGR2H472#F126
	5 600	19.1	44.0	11	13	20	0.20	77x188	VGR2H562#E188
		21.2	48.8	11	13	20	0.20	90x150	VGR2H562#F150
	6 800	23.2	53.4	9	10	20	0.20	90x167	VGR2H682#F167
8 200	25.3	58.2	8	8	20	0.20	90x190	VGR2H822#F190	
10 000	27.0	62.1	7	7	20	0.20	90x268	VGR2H103#F268	
12 000	29.8	68.5	5	6	20	0.20	90x230	VGR2H123#F230	
14 000	29.6	68.1	5	6	20	0.20	90x268	VGR2H143#F268	

\* Please contact us if load condition exceeds terminals related  $I_{r,max}$  referred on page 13

Additional designs on request · Weitere Designs auf Anfrage

## > Ripple Current Multiplier · Wechselstrommultiplikator

Frequency [Hz]	50/60	120	300	1k	≥ 10k
Multiplier	0.80	1.00	1.18	1.34	1.45

Ta (°C)	40	50	60	65	70	75	80	85	90	95	100	105
Multiplier	2.3	2.1	2.0	1.9	1.9	1.8	1.7	1.6	1.4	1.2	1.1	1.0

Forced cooling – Wind speed [m/sec]	v < 0.25	v ≥ 0.25	v ≥ 0.5	v ≥ 1.0	v ≥ 2.0	v ≥ 3.0
Multiplier	1.00	1.07	1.15	1.25	1.30	1.35

Water cooled heatsink – size ratio [L/D]	1.10	1.25	1.40	1.55	1.70	2.00	2.50	3.00
Multiplier	2.0	1.9	1.7	1.6	1.5	1.4	1.2	1.1

> Life Time Table · Brauchbarkeitsdauer – Tabelle

VGR	Useful life as function of ambient temperature and ripple current												
	$I_r$ at 105°C	x 1.0	x 1.1	x 1.2	x 1.4	x 1.6	x 1.7	x 1.8	x 1.9	x 2.0	x 2.1	x 2.2	x 2.3
$T_a = 40^\circ\text{C}$	250	250	250	250	250	250	250	250	250	213	152	106	73
$T_a = 45^\circ\text{C}$	250	250	250	250	250	250	250	250	186	135	96	67	
$T_a = 50^\circ\text{C}$	250	250	250	250	250	213	160	117	85	61			
$T_a = 55^\circ\text{C}$	250	250	250	250	177	135	101	74	54	38			
$T_a = 60^\circ\text{C}$	250	250	250	184	112	85	64	47	34				
$T_a = 65^\circ\text{C}$	250	216	178	116	70	54	40	29					
$T_a = 70^\circ\text{C}$	162	136	113	73	44	34	25	18					
$T_a = 75^\circ\text{C}$	102	86	71	46	28	21	16						
$T_a = 80^\circ\text{C}$	64	54	45	29	17	13							
$T_a = 85^\circ\text{C}$	41	34	28	18	11								
$T_a = 90^\circ\text{C}$	25	21	18	11									
$T_a = 95^\circ\text{C}$	16	13	11										
$T_a = 100^\circ\text{C}$	10	8											
$T_a = 105^\circ\text{C}$	6												

khrs      Max. value limited to 250 000 hours.

> Life Time Graph · Brauchbarkeitsdauer – Diagramm

Useful life depending on ambient temperature  $T_a$  and ripple current operating conditions  $I_r$  versus rated ripple current at the upper category temperature  $I_r, 105^\circ\text{C}, 120\text{Hz}$

Brauchbarkeitsdauer in Abhängigkeit von Umgebungstemperatur  $T_a$  und Wechselstrombelastung  $I_r$  im Verhältnis zur max. Wechselstrombelastung bei oberer Kategorietemperatur  $I_r, 105^\circ\text{C}, 120\text{Hz}$

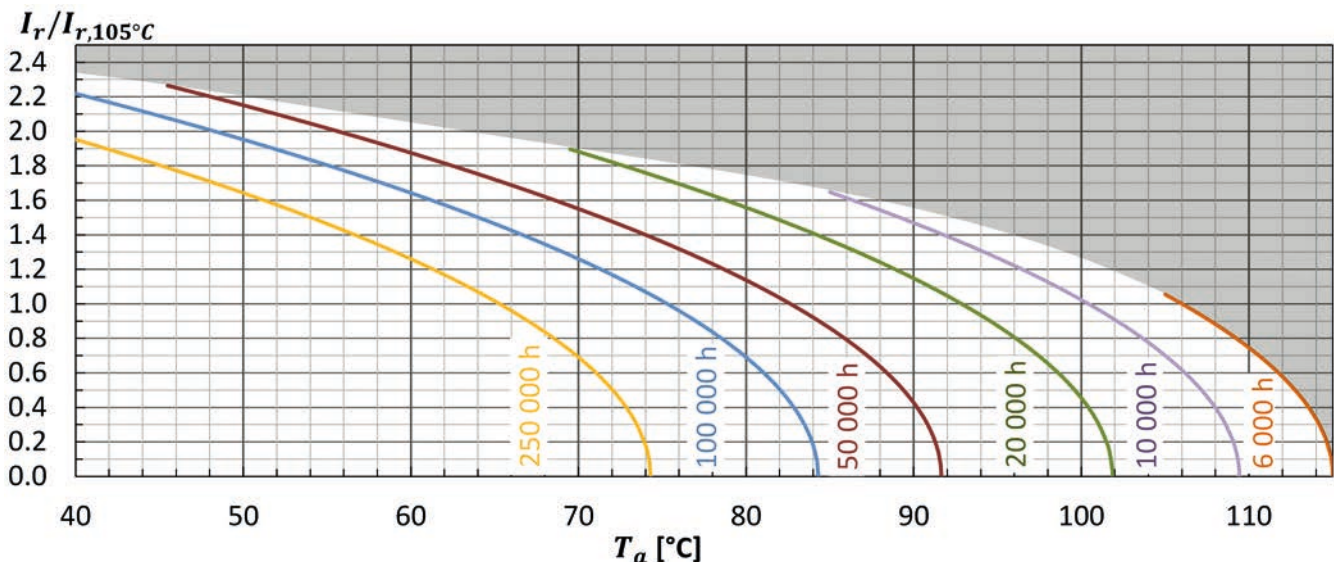

> Life Time Tests and Requirements · Anforderungen Brauchbarkeitsdauer

Life time test	Test procedure	End of Life criteria
Endurance test	$T_a = 105^\circ\text{C}$ ; $V_r, I_r$ applied 4000 hours	$\Delta C/C \leq 10\%$ (of initial value) $\text{Tan}\delta \leq 175\%$ (of specified value) $I_L \leq$ specified value
Useful life	$T_a = 105^\circ\text{C}$ ; $V_r, I_r$ applied 6000 hours	$\Delta C/C \leq 15\%$ (of initial value) $\text{Tan}\delta < 200\%$ (of specified value) $I_L \leq$ specified value

Reference Specification: JIS C 5101-4, JIS C 5102, IEC 60384-4