

# VGLR · Screw-Terminal · 12000 h/105 °C

Long Life · High Ripple Current · Bottom cooling design · Low ESR

## > Specifications · Spezifikationen

Items	Characteristics
Temperature range	-40°C ~ + 105°C
Capacitance tolerance (at 20°C)	Standard +/- 20%, -10/+30% on request
Surge voltage / Ripple voltage	Repetitive max. 30 sec per 6 Minutes / ≤ 50V
Leakage current max. $I_L$ (20°C, 5 min)	0.01 • C • $V_r$ [μA] or 5 mA, which is smaller.
Useful life	12 000 hours at 105°C
Field failure rate	0.5 FIT = 0.5 • 10 <sup>-9</sup> Failures/hour
Reference standards	IEC 60384-4, JIS C 5101-4
Vibration	0.75mm, 10...55Hz, 10g, 3x2h
Outer materials	UL94-V0/UL224-VW1 certified (cap/sleeve)
Sleeve withstanding voltage	4000 Vac/ 1min between terminals bundled and plate*
Product Compliance	RoHS, REACH, Conflict Minerals a.o. – refer to p. 14–15

\* Typical value



## > Shape designation · Formbezeichnung

- additional information on p. 12–13 · Zusatzinformationen auf S. 12–13
- mounting accessories from p. 219 · Montagezubehör ab S. 219

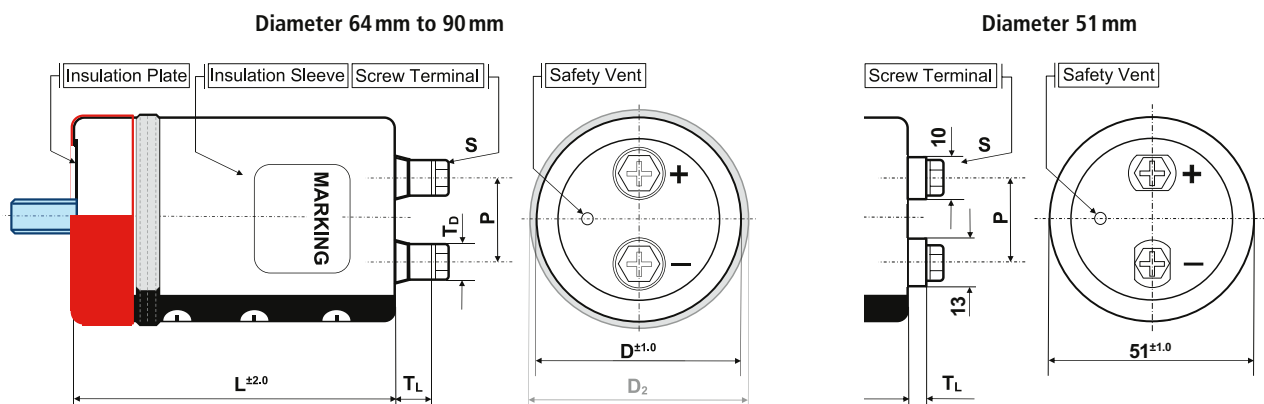

Shape code Features	B Bolt	I/Y double sleeve for 2/3 points metal Bracket	N + suffix WC blank bottom + seating ring	N standard
outer insulation sleeve	•	•	•	•
insulation plate	•	•		•
stud bolt	•			
bottom double sleeve		•		
integrated seating ring			•	

diameter code	ØD	available shape	P	S	T <sub>L</sub>	T <sub>D</sub>	Cap material
C	51	B, N, I, Y	22.0	M5x10	4.5	13/10	PH
D	64	B, N, I, Y	28.6	M5x10	8.0	11	PH
E	77	B, N, I, Y, WC	31.5	M6x12	9.0	12	PH
F	90	B, N, I, Y, WC	31.5	M6x12	8.0	12	PH

Size in mm

## > Product Code · Bestellbezeichnung

**Example:** Series VGLR · 12000 µF +/- 20 % · 400 V · D=90 mm · L= 190 mm for bottom cooling

<b>VGLR</b>	<b>2G</b>	<b>123</b>	<b>N</b>	<b>F</b>	<b>190</b>	<b>WC</b>
Series name	Capacitance code		Shape code	Diameter code	Capacitance tolerance	Specific features
Rated voltage code						
Code	Voltage	Code	Voltage			
2V	350	2W	450			
2G	400	2H	500			
					∅ : ± 20 %	
					Q : -10 % ~ +30 %	
					Case length code – length in mm (3 digits)	

Rated Voltage Code (Surge Voltage) $V_r$ [V DC]	Capacitance $C_r$ [µF]	Ripple Current at 105°C/120Hz $I_r$ [A RMS]	Ripple Current at 40°C/120Hz [A RMS]	ESR (typ) at 20°C/100Hz [mΩ]	Zmax at 20°C/10kHz [mΩ]	ESL (typ) [nH]	Dissipation Factor at 20°C/120Hz Tan δ	DxL [mm]	Product Code  # = variable value, see fixing code in the product code
<b>350 VDC</b> Code: 2V  Surge Voltage 400 VDC	1 800	9.1	21.0	30	31	17	0.20	51x96	VGLR2V182#C096
	2 200	9.8	22.6	25	26	17	0.20	51x96	VGLR2V222#C096
		10.2	23.5	25	26	17	0.20	51x109	VGLR2V222#C109
	2 700	11.0	25.3	20	21	17	0.20	51x109	VGLR2V272#C109
		11.4	26.3	20	21	17	0.20	51x125	VGLR2V272#C125
	3 300	12.2	28.1	16	19	17	0.20	51x125	VGLR2V332#C125
		15.1	34.8	16	19	18	0.20	64x107	VGLR2V332#D107
	3 900	16.5	38.0	14	16	18	0.20	64x107	VGLR2V392#D107
		16.8	38.7	14	16	18	0.20	64x123	VGLR2V392#D123
	4 700	18.3	42.1	11	13	18	0.20	64x123	VGLR2V472#D123
		20.6	47.4	11	13	20	0.20	77x108	VGLR2V472#E108
	5 600	20.1	46.3	10	10	18	0.20	64x147	VGLR2V562#D147
		22.8	52.5	10	10	20	0.20	77x108	VGLR2V562#E108
	6 800	22.3	51.3	8	10	18	0.20	64x164	VGLR2V682#D164
		25.1	57.8	8	10	20	0.20	77x124	VGLR2V682#E124
	8 200	28.6	65.8	8	10	20	0.20	90x110	VGLR2V682#F110
		24.8	57.1	7	7	18	0.20	64x187	VGLR2V822#D187
		27.6	63.5	7	7	20	0.20	77x148	VGLR2V822#E148
	10 000	31.3	72.0	7	7	20	0.20	90x110	VGLR2V822#F110
		30.6	70.4	5	6	20	0.20	77x165	VGLR2V103#E165
34.3		78.9	5	6	20	0.20	90x150	VGLR2V103#F150	
12 000	33.8	77.8	5	5	20	0.20	77x188	VGLR2V123#E188	
	37.6	86.5	5	5	20	0.20	90x150	VGLR2V123#F150	
15 000	39.2	90.2	4	4	20	0.20	77x228	VGLR2V153#E228	
	41.6	95.7	4	4	20	0.20	90x167	VGLR2V153#F167	
18 000	45.3	104.2*	3	4	20	0.20	90x190	VGLR2V183#F190	
22 000	48.3	111.1*	3	3	20	0.20	90x268	VGLR2V223#F268	
27 000	50.0	115.0*	2	3	20	0.20	90x268	VGLR2V273#F268	
<b>400 VDC</b> Code: 2G Surge Voltage 450 VDC	1 500	8.4	19.4	35	38	17	0.20	51x96	VGLR2G152#C096
	1 800	9.1	21.0	30	32	17	0.20	51x96	VGLR2G182#C096
		9.4	21.7	30	32	17	0.20	51x109	VGLR2G182#C109
2 200	10.2	23.5	24	26	17	0.20	51x109	VGLR2G222#C109	

Additional designs on request · Weitere Designs auf Anfrage

# VGLR · Screw-Terminal · 12000 h/105 °C

Rated VoltageCode (Surge Voltage) $V_r$ [V DC]	Capacitance $C_r$ [ $\mu$ F]	Ripple Current at 105°C/120Hz $I_r$ [A RMS]	Ripple Current at 40°C/120Hz [A RMS]	ESR (typ) at 20°C/100Hz [m $\Omega$ ]	Zmax at 20°C/10kHz [m $\Omega$ ]	ESL (typ) [nH]	Dissipation Factor at 20°C/120Hz Tan $\delta$	DxL [mm]	Product Code  # = variable value, see fixing code in the product code
<b>400 VDC</b> Code: 2G  Surge Voltage 450 VDC	2 200	10.6	24.4	24	26	17	0.20	51x125	VGLR2G222#C125
		11.4	26.3	20	22	17	0.20	51x125	VGLR2G272#C125
	2 700	13.6	31.3	20	22	18	0.20	64x107	VGLR2G272#D107
		15.2	35.0	16	18	18	0.20	64x107	VGLR2G332#D107
	3 300	16.7	38.5	14	16	18	0.20	64x123	VGLR2G392#D123
		18.8	43.3	14	16	20	0.20	77x108	VGLR2G392#E108
	4 700	18.4	42.4	11	12	18	0.20	64x147	VGLR2G472#D147
		20.9	48.1	11	12	20	0.20	77x108	VGLR2G472#E108
	5 600	20.2	46.5	10	11	18	0.20	64x164	VGLR2G562#D164
		23.1	53.2	10	11	20	0.20	77x124	VGLR2G562#E124
		26.0	59.8	10	11	20	0.20	90x110	VGLR2G562#F110
	6 800	22.6	52.0	8	9	20	0.20	64x187	VGLR2G682#D187
		25.1	57.8	8	9	20	0.20	77x148	VGLR2G682#E148
		28.5	65.6	8	9	20	0.20	90x110	VGLR2G682#F110
	8 200	27.3	62.8	7	8	20	0.20	77x148	VGLR2G822#E148
		31.0	71.3	7	8	20	0.20	90x150	VGLR2G822#F150
	10 000	30.9	71.1	5	6	20	0.20	77x188	VGLR2G103#E188
		34.3	78.9	5	6	20	0.20	90x150	VGLR2G103#F150
12 000	37.2	85.6	5	5	20	0.20	90x167	VGLR2G123#F167	
15 000	41.4	95.3	4	4	20	0.20	90x190	VGLR2G153#F190	
18 000	43.7	100.6*	3	4	20	0.20	90x268	VGLR2G183#F268	
22 000	45.1	103.8*	3	3	20	0.20	90x268	VGLR2G223#F268	
<b>450 VDC</b> Code: 2W  Surge Voltage 500 VDC	1 200	7.9	18.2	44	47	17	0.20	51x96	VGLR2W122#C096
		8.7	20.1	35	37	17	0.20	51x96	VGLR2W152#C096
	1 500	9.0	20.7	35	37	17	0.20	51x109	VGLR2W152#C109
		9.7	22.4	30	31	17	0.20	51x109	VGLR2W182#C109
	1 800	10.1	23.3	30	31	17	0.20	51x125	VGLR2W182#C125
		10.9	25.1	24	27	17	0.20	51x125	VGLR2W222#C125
	2 200	12.6	29.0	24	27	18	0.20	64x107	VGLR2W222#D107
		14.9	34.3	24	27	20	0.20	77x77	VGLR2W222#E077
	2 700	14.1	32.5	20	22	18	0.20	64x107	VGLR2W272#D107
		16.1	37.1	20	22	20	0.20	77x108	VGLR2W272#E108
	3 300	15.8	36.4	16	18	18	0.20	64x123	VGLR2W332#D123
		18.5	42.6	16	18	20	0.20	77x108	VGLR2W332#E108
		13.1	30.2	16	18	20	0.20	90x97	VGLR2W332#F097
	3 900	17.2	39.6	14	16	18	0.20	64x147	VGLR2W392#D147
		19.6	45.1	14	16	20	0.20	77x124	VGLR2W392#E124
		22.3	51.3	14	16	20	0.20	90x110	VGLR2W392#F110
	4 700	19.0	43.7	11	12	18	0.20	64x164	VGLR2W472#D164
		21.5	49.5	11	12	20	0.20	77x148	VGLR2W472#E148
24.4		56.2	11	12	20	0.20	90x110	VGLR2W472#F110	
5 600	21.1	48.6	10	10	18	0.20	64x187	VGLR2W562#D187	
	23.5	54.1	10	10	20	0.20	77x148	VGLR2W562#E148	
	26.5	61.0	10	10	20	0.20	90x126	VGLR2W562#F126	

Additional designs on request · Weitere Designs auf Anfrage

# VGLR · Screw-Terminal · 12000 h/105 °C

Rated VoltageCode (Surge Voltage) $V_r$ [V DC]	Capacitance $C_r$ [ $\mu$ F]	Ripple Current at 105°C/120Hz $I_r$ [A RMS]	Ripple Current at 40°C/120Hz [A RMS]	ESR (typ) at 20°C/100Hz [m $\Omega$ ]	Zmax at 20°C/10kHz [m $\Omega$ ]	ESL (typ) [nH]	Dissipation Factor at 20°C/120Hz Tan $\delta$	DxL [mm]	Product Code # = variable value, see fixing code in the product code
<b>450 VDC</b> Code: 2W  Surge Voltage 500 VDC	6 000	24.0	55.2	9	10	20	0.20	77x148	VGLR2W602#E148
	6 800	25.9	59.6	8	9	20	0.20	77x165	VGLR2W682#E165
		29.0	66.7	8	9	20	0.20	90x150	VGLR2W682#F150
	8 200	28.7	66.1	7	7	20	0.20	77x188	VGLR2W822#E188
		31.6	72.7	7	7	20	0.20	90x167	VGLR2W822#F167
	10 000	34.7	79.9	5	6	20	0.20	90x190	VGLR2W103#F190
	15 000	41.0	94.3	4	5	20	0.20	90x268	VGLR2W153#F268
18 000	41.9	96.4	3	4	20	0.20	90x268	VGLR2W183#F268	
<b>500 VDC</b> Code: 2H  Surge Voltage 550 VDC	680	4.6	10.6	85	90	17	0.20	51x96	VGLR2H681#C096
	820	5.0	11.5	70	74	17	0.20	51x96	VGLR2H821#C096
		5.2	12.0	70	74	17	0.20	51x109	VGLR2H821#C109
	1 000	5.7	13.2	58	61	17	0.20	51x109	VGLR2H102#C109
	1 200	6.4	14.8	48	51	17	0.20	51x125	VGLR2H122#C125
	1 500	8.4	19.4	38	41	18	0.20	64x107	VGLR2H152#D107
	1 800	9.3	21.4	32	34	18	0.20	64x107	VGLR2H182#D107
	2 200	10.3	23.7	26	30	18	0.20	64x123	VGLR2H222#D123
		11.7	27.0	26	30	20	0.20	77x108	VGLR2H222#E108
	2 700	11.5	26.5	22	23	18	0.20	64x147	VGLR2H272#D147
		13.1	30.2	22	23	20	0.20	77x108	VGLR2H272#E108
	3 300	13.0	29.9	18	19	18	0.20	64x187	VGLR2H332#D187
		14.5	33.4	18	19	20	0.20	77x124	VGLR2H332#E124
		16.5	38.0	18	19	20	0.20	90x110	VGLR2H332#F110
	3 900	15.8	36.4	15	16	20	0.20	77x148	VGLR2H392#E148
		17.9	41.2	15	16	20	0.20	90x110	VGLR2H392#F110
	4 400	16.6	38.2	14	15	20	0.20	77x148	VGLR2H442#E148
	4 700	17.3	39.8	13	13	20	0.20	77x165	VGLR2H472#E165
		19.6	45.1	13	13	20	0.20	90x126	VGLR2H472#F126
	5 600	19.1	44.0	11	11	20	0.20	77x188	VGLR2H562#E188
		21.2	48.8	11	11	20	0.20	90x150	VGLR2H562#F150
	6 800	21.8	50.2	9	10	20	0.20	77x228	VGLR2H682#E228
		23.2	53.4	9	10	20	0.20	90x167	VGLR2H682#F167
	7 500	24.2	55.7	9	10	20	0.20	90x190	VGLR2H752#F190
8 200	25.3	58.2	8	9	20	0.20	90x190	VGLR2H822#F190	
10 000	27.0	62.1	7	7	20	0.20	90x268	VGLR2H103#F268	
11 000	28.6	65.8	6	7	20	0.20	90x230	VGLR2H113#F230	
12 000	27.7	63.8	5	5	20	0.20	90x268	VGLR2H123#F268	

\* Please contact us if load condition exceeds terminals related  $I_{r,max}$  referred on page 13

Additional designs on request · Weitere Designs auf Anfrage

## > Ripple Current Multiplier · Wechselstrommultiplikator

Frequency [Hz]	50/60		120		300		1k		≥ 10k			
Multiplier	0.80		1.00		1.18		1.34		1.45			
Ta (°C)	40	50	60	65	70	75	80	85	90	95	100	105
Multiplier	2.3	2.1	2.0	1.9	1.9	1.8	1.7	1.6	1.4	1.2	1.1	1.0
Forced cooling – Wind speed [m/sec]	v < 0.25		v ≥ 0.25		v ≥ 0.5		v ≥ 1.0		v ≥ 2.0		v ≥ 3.0	
Multiplier	1.00		1.07		1.15		1.25		1.30		1.35	
Water cooled heatsink – size ratio [L/D]	1.10	1.25	1.40	1.55	1.70	2.00	2.50	3.00				
Multiplier	2.0	1.9	1.7	1.6	1.5	1.4	1.2	1.1				

## > Life Time Table · Brauchbarkeitsdauer – Tabelle

VGLR	Useful life as function of ambient temperature and ripple current												
	I <sub>r</sub> at 105°C	x 1.0	x 1.1	x 1.2	x 1.4	x 1.6	x 1.7	x 1.8	x 1.9	x 2.0	x 2.1	x 2.2	x 2.3
T <sub>a</sub> = 40°C	250	250	250	250	250	250	250	250	250	250	250	213	147
T <sub>a</sub> = 45°C	250	250	250	250	250	250	250	250	250	250	192	135	
T <sub>a</sub> = 50°C	250	250	250	250	250	250	250	250	235	171	122		
T <sub>a</sub> = 55°C	250	250	250	250	250	250	202	149	108	77			
T <sub>a</sub> = 60°C	250	250	250	250	224	170	128	94	68				
T <sub>a</sub> = 65°C	250	250	250	232	141	108	81	59					
T <sub>a</sub> = 70°C	250	250	226	147	89	68	51	37					
T <sub>a</sub> = 75°C	205	172	142	93	56	43	32						
T <sub>a</sub> = 80°C	129	109	90	58	35	27							
T <sub>a</sub> = 85°C	82	69	57	37	22								
T <sub>a</sub> = 90°C	51	43	36	23									
T <sub>a</sub> = 95°C	32	27	22										
T <sub>a</sub> = 100°C	20	17											
T <sub>a</sub> = 105°C	12												

khrs      Max. value limited to 250 000 hours.

> Life Time Graph · Brauchbarkeitsdauer – Diagramm

Useful life depending on ambient temperature  $T_a$  and ripple current operating conditions  $I_r$  versus rated ripple current at the upper category temperature  $I_{r, 105^\circ\text{C}, 120\text{Hz}}$

Brauchbarkeitsdauer in Abhängigkeit von Umgebungstemperatur  $T_a$  und Wechselstrombelastung  $I_r$  im Verhältnis zur max. Wechselstrombelastung bei oberer Kategorie-temperatur  $I_{r, 105^\circ\text{C}, 120\text{Hz}}$

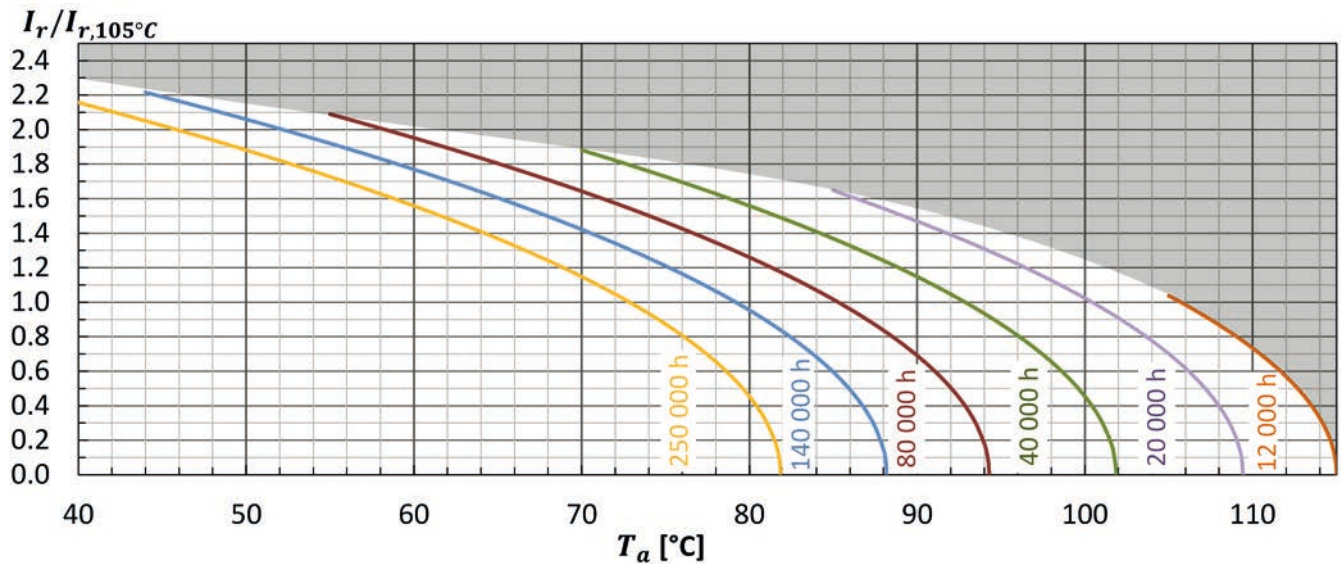

> Life Time Tests and Requirements · Anforderungen Brauchbarkeitsdauer

Life time test	Test procedure	End of Life criteria
Endurance test	$T_a = 105^\circ\text{C}$ ; $V_r, I_r$ applied 8000 hours	$\Delta C/C \leq 10\%$ (of initial value) $\text{Tan}\delta \leq 175\%$ (of specified value) $I_L \leq$ specified value
Useful life	$T_a = 105^\circ\text{C}$ ; $V_r, I_r$ applied 12000 hours	$\Delta C/C \leq 15\%$ (of initial value) $\text{Tan}\delta < 200\%$ (of specified value) $I_L \leq$ specified value

Reference Specification: JIS C 5101-4, JIS C 5102, IEC 60384-4