

VFR · Screw-Terminal · 6000 h/85 °C

High Ripple Current · Bottom cooling design · Low ESR

Optional design for permanent and deep charge-discharge application with high voltage hub and pulsed operation mode upon request.

Spezielles Design für häufige und tiefe Lade-, Entladeanwendungen mit hohem Spannungshub und Impulsbetrieb auf Anfrage erhältlich.

> Specifications · Spezifikationen

Items	Characteristics
Temperature range	-40°C ~ + 85°C
Capacitance tolerance (at 20°C)	Standard +/- 20%, -10/+30% on request
Surge voltage / Ripple voltage	Repetitive max. 30 sec per 6 Minutes / ≤ 70V
Leakage current max. I _L (20°C, 5 min)	0.01 • C • V, [μA] or 5 mA, which is smaller.
Useful life	6000 hours at 85°C
Field failure rate	0.5 FIT = 0.5 • 10 ⁻⁹ Failures/hour
Reference standards	IEC 60384-4, JIS C 5101-4
Vibration	0.75mm, 10...55Hz, 10g, 3x2h
Outer materials	UL94-V0/UL224-VW1 certified (cap/sleeve)
Sleeve withstanding voltage	4000 Vac/1min between terminals bundled and plate*
Product Compliance	RoHS, REACH, Conflict Minerals a.o. – refer to p. 14–15

* Typical value



> Shape designation · Formbezeichnung

- additional information on p. 12–13 · Zusatzinformationen auf S. 12–13
- mounting accessories from p. 219 · Montagezubehör ab S. 219

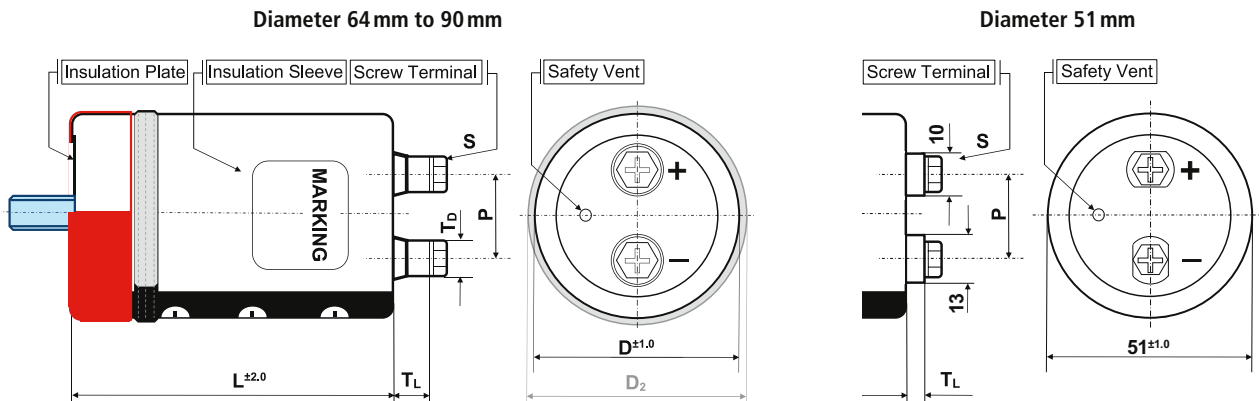

Shape code Features	B Bolt	I/Y double sleeve for 2/3 points metal Bracket	N + suffix WC blank bottom + seating ring	N standard
outer insulation sleeve	•	•	•	•
insulation plate	•	•		•
stud bolt	•			
bottom double sleeve		•		
integrated seating ring			•	

diameter code	ØD	available shape	P	S	T _L	T _D	Cap material
C	51	B, N, I, Y	22.0	M5x10	4.5	13/10	PH
D	64	B, N, I, Y	28.6	M5x10	8.0	11	PH
E	77	B, N, I, Y, WC	31.5	M6x12	9.0	12	PH
F	90	B, N, I, Y, WC	31.5	M6x12	8.0	12	PH

Size in mm

> Product Code · Bestellbezeichnung

Example: Series VFR · 12000 µF +/- 20 % · 400 V · D=90 mm · L= 167 mm with Y-Bracket

VFR	2G	123	Y	F	167
Series name	Capacitance code	Shape code	Diameter code	Capacitance tolerance	Specific features
Rated voltage code					
Code	Voltage	Code	Voltage	Case length code – length in mm (3 digits)	
2V	350	2W	450	Ø : ± 20 % Q : -10 % ~ +30 %	
2G	400	2H	500		

Rated VoltageCode (Surge Voltage) V_r [V DC]	Capacitance C_r [µF]	Ripple Current at 85°C/120Hz I_r [A RMS]	Ripple Current at 40°C/120Hz [A RMS]	ESR (typ) at 20°C/100Hz [mΩ]	Zmax at 20°C/10kHz [mΩ]	ESL (typ) [nH]	Dissipation Factor at 20°C/120Hz Tan δ	DxL [mm]	Product Code # = variable value, see fixing code in the product code
350 VDC Code: 2V Surge Voltage 400 VDC	2 200	10.2	21.5	24	26	17	0.20	51x96	VFR2V222#C096
	2 700	11.0	23.1	20	22	17	0.20	51x96	VFR2V272#C096
	3 300	12.2	25.6	29	30	17	0.20	51x109	VFR2V332#C109
		13.3	27.9	14	16	17	0.20	51x125	VFR2V392#C125
	3 900	17.0	35.7	14	16	18	0.20	64x107	VFR2V392#D107
		18.9	39.7	11	13	18	0.20	64x107	VFR2V472#D107
	5 600	20.8	43.7	10	11	18	0.20	64x123	VFR2V562#D123
		23.5	49.4	10	11	20	0.20	77x108	VFR2V562#E108
	6 800	23.1	48.5	8	10	18	0.20	64x147	VFR2V682#D147
		26.2	55.0	8	10	20	0.20	77x108	VFR2V682#E108
	8 200	25.4	53.3	7	8	18	0.20	64x164	VFR2V822#D164
		28.7	60.3	7	8	20	0.20	77x124	VFR2V822#E124
	10 000	32.6	68.5	7	8	20	0.20	90x110	VFR2V822#F110
		28.5	59.9	5	7	18	0.20	64x187	VFR2V103#D187
	12 000	31.7	66.6	5	7	20	0.20	77x148	VFR2V103#E148
		36.0	75.6	5	7	20	0.20	90x110	VFR2V103#F110
	15 000	34.8	73.1	5	5	20	0.20	77x165	VFR2V123#E165
		39.3	82.5	5	5	20	0.20	90x126	VFR2V123#F126
	18 000	39.3	82.5	4	5	20	0.20	77x188	VFR2V153#E188
		43.6	91.6	4	5	20	0.20	90x150	VFR2V153#F150
22 000	47.3	99.3	3	4	20	0.20	90x167	VFR2V183#F167	
27 000	52.1	109.4	3	4	20	0.20	90x190	VFR2V223#F190	
33 000	56.0	117.6*	2	3	20	0.20	90x268	VFR2V273#F268	
	57.7	121.2*	2	3	20	0.20	90x268	VFR2V333#F268	
400 VDC Code: 2G Surge Voltage 450 VDC	1 800	9.5	20.0	30	32	17	0.20	51x96	VFR2G182#C096
	2 200	10.2	21.4	25	27	17	0.20	51x96	VFR2G222#C096
	2 700	11.4	23.9	20	22	17	0.20	51x109	VFR2G272#C109
	3 300	12.7	26.7	16	18	17	0.20	51x125	VFR2G332#C125
		15.7	33.0	16	18	18	0.20	64x107	VFR2G332#D107
	3 900	17.1	35.9	14	16	18	0.20	64x95	VFR2G392#D095
20.0		42.0	14	16	20	0.20	77x105	VFR2G392#E105	

Additional designs on request · Weitere Designs auf Anfrage

VFR · Screw-Terminal · 6000 h/85 °C

Rated VoltageCode (Surge Voltage) V_r [V DC]	Capacitance C_r [μ F]	Ripple Current at 85°C/120Hz I_r [A RMS]	Ripple Current at 40°C/120Hz [A RMS]	ESR (typ) at 20°C/100Hz [m Ω]	Zmax at 20°C/10kHz [m Ω]	ESL (typ) [nH]	Dissipation Factor at 20°C/120Hz Tan δ	DxL [mm]	Product Code # = variable value, see fixing code in the product code
400 VDC Code: 2G Surge Voltage 450 VDC	4 700	19.0	39.9	11	13	18	0.20	64x123	VFR2G472#D123
		21.5	45.2	11	13	20	0.20	77x108	VFR2G472#E108
	5 600	20.9	43.9	10	11	18	0.20	64x147	VFR2G562#D147
		23.8	50.0	10	11	20	0.20	77x108	VFR2G562#E108
	6 800	23.2	48.7	8	10	18	0.20	64x164	VFR2G682#D164
		26.2	55.0	8	10	20	0.20	77x124	VFR2G682#E124
		29.7	62.4	8	10	20	0.20	90x110	VFR2G682#F110
	8 200	25.8	54.2	7	8	18	0.20	64x187	VFR2G822#D187
		28.7	60.3	7	8	20	0.20	77x148	VFR2G822#E148
		32.6	68.5	7	8	20	0.20	90x110	VFR2G822#F110
	10 000	31.8	66.8	5	7	20	0.20	77x165	VFR2G103#E165
		35.9	75.4	5	7	20	0.20	90x126	VFR2G103#F126
	12 000	35.1	73.7	5	5	20	0.20	77x188	VFR2G123#E188
		39.0	81.9	5	5	20	0.20	90x150	VFR2G123#F150
	15 000	43.2	90.7	4	5	20	0.20	90x167	VFR2G153#F167
	18 000	47.0	98.7	3	4	20	0.20	90x190	VFR2G183#F190
22 000	50.5	106.1*	3	4	20	0.20	90x268	VFR2G223#F268	
27 000	52.0	109.2*	2	3	20	0.20	90x268	VFR2G273#F268	
450 VDC Code: 2W Surge Voltage 500 VDC	1 500	9.0	18.9	35	38	17	0.20	51x96	VFR2W152#C096
	1 800	9.7	20.4	30	32	17	0.20	51x96	VFR2W182#C096
	2 200	10.9	22.9	24	26	17	0.20	51x109	VFR2W222#C109
	3 300	16.2	34.0	16	18	18	0.20	64x107	VFR2W332#D107
		16.5	34.7	16	18	18	0.20	64x123	VFR2W332#D123
	3 900	17.8	37.4	14	16	18	0.20	64x123	VFR2W392#D123
		20.1	42.2	14	16	20	0.20	77x108	VFR2W392#E108
	4 700	19.6	41.2	11	13	18	0.20	64x147	VFR2W472#D147
		22.3	46.8	11	13	24	0.20	77x108	VFR2W472#E108
	5 600	21.6	45.4	10	11	18	0.20	64x164	VFR2W562#D164
		24.3	51.0	10	11	20	0.20	77x124	VFR2W562#E124
		27.6	58.0	10	11	20	0.20	90x110	VFR2W562#F110
	6 800	24.1	50.6	8	10	18	0.20	64x187	VFR2W682#D187
		26.8	56.3	8	10	20	0.20	77x148	VFR2W682#E148
		30.4	63.8	8	10	20	0.20	90x110	VFR2W682#F110
	8 200	29.5	62.0	7	8	20	0.20	77x165	VFR2W822#E165
		33.4	70.1	7	8	20	0.20	90x126	VFR2W822#F126
	10 000	32.9	69.1	5	7	20	0.20	77x188	VFR2W103#E188
		36.5	76.7	5	7	20	0.20	90x150	VFR2W103#F150
	12 000	39.6	83.2	5	5	20	0.20	90x167	VFR2W123#F167
14 000	42.5	89.3	4	5	20	0.20	90x190	VFR2W143#F190	
15 000	44.1	92.6	4	5	20	0.20	90x190	VFR2W153#F190	
17 000	44.5	93.4	4	5	20	0.20	90x230	VFR2W173#F230	
18 000	46.9	98.5	3	4	20	0.20	90x268	VFR2W183#F268	
22 000	48.2	101.2*	3	4	20	0.20	90x268	VFR2W223#F268	

Additional designs on request · Weitere Designs auf Anfrage

Rated VoltageCode (Surge Voltage) V_r [V DC]	Capacitance C_r [μ F]	Ripple Current at 85°C/120Hz I_r [A RMS]	Ripple Current at 40°C/120Hz [A RMS]	ESR (typ) at 20°C/100Hz [m Ω]	Zmax at 20°C/10kHz [m Ω]	ESL (typ) [nH]	Dissipation Factor at 20°C/120Hz Tan δ	DxL [mm]	Product Code # = variable value, see fixing code in the product code
500 VDC Code: 2H Surge Voltage 550 VDC	820	6.1	12.9	71	74	17	0.20	51x96	VFR2H821#C096
	1 000	6.7	14.1	58	61	17	0.20	51x96	VFR2H102#C096
	1 200	7.6	16.0	48	51	17	0.20	51x109	VFR2H122#C109
	1 500	8.7	18.3	40	43	17	0.20	51x125	VFR2H152#C125
	1 800	11.3	23.7	32	35	18	0.20	64x107	VFR2H182#D107
	2 200	12.6	26.5	22	24	18	0.20	64x107	VFR2H222#D107
	2 700	14.0	29.4	22	24	18	0.20	64x123	VFR2H272#D123
		15.9	33.4	22	24	20	0.20	77x108	VFR2H272#E108
	3 300	15.6	32.8	18	20	18	0.20	64x147	VFR2H332#D147
		17.8	37.4	18	20	20	0.20	77x108	VFR2H332#E108
	3 900	17.1	35.9	15	17	18	0.20	64x164	VFR2H392#D164
		19.3	40.5	15	17	20	0.20	77x124	VFR2H392#E124
		21.9	46.0	15	17	20	0.20	90x110	VFR2H392#F110
	4 700	19.0	39.9	13	15	18	0.20	64x187	VFR2H472#D187
		21.2	44.5	13	15	20	0.20	77x148	VFR2H472#E148
		24.0	50.4	13	15	20	0.20	90x110	VFR2H472#F110
	5 600	23.2	48.7	11	13	20	0.20	77x165	VFR2H562#E165
		26.1	54.8	11	13	20	0.20	90x126	VFR2H562#F126
	6 800	25.8	54.2	9	10	20	0.20	77x188	VFR2H682#E188
		28.6	60.1	9	10	20	0.20	90x150	VFR2H682#F150
8 200	31.1	65.3	8	8	20	0.20	90x167	VFR2H822#F167	
10 000	34.2	71.8	6	7	20	0.20	90x190	VFR2H103#F190	
12 000	36.3	76.2	5	6	20	0.20	90x268	VFR2H123#F268	
15 000	37.8	79.4	4	5	20	0.20	90x268	VFR2H153#F268	

* Please contact us if load condition exceeds terminals related $I_{r,max}$ referred on page 13

Additional designs on request · Weitere Designs auf Anfrage

> Ripple Current Multiplier · Wechselstrommultiplikator

Frequency [Hz]	50/60		120		300		1k		≥ 10k	
Multiplier	0.80		1.00		1.18		1.34		1.45	

Ta (°C)	40	45	50	55	60	65	70	75	80	85
Multiplier	2.1	2.1	2.0	1.9	1.8	1.6	1.5	1.3	1.1	1.0

Forced cooling – Wind speed [m/sec]	v < 0.25	v ≥ 0.25	v ≥ 0.5	v ≥ 1.0	v ≥ 2.0	v ≥ 3.0
Multiplier	1.00	1.07	1.15	1.25	1.30	1.35

Water cooled heatsink – size ratio [L/D]	1.10	1.25	1.40	1.55	1.70	2.00	2.50	3.00
Multiplier	2.0	1.9	1.7	1.6	1.5	1.4	1.2	1.1

> Life Time Table · Brauchbarkeitsdauer – Tabelle

VFR	Useful life as function of ambient temperature and ripple current											
	$x 1.0$	$x 1.1$	$x 1.2$	$x 1.3$	$x 1.4$	$x 1.5$	$x 1.6$	$x 1.7$	$x 1.8$	$x 1.9$	$x 2.0$	$x 2.1$
$T_a = 40^\circ\text{C}$	250	250	250	208	159	120	88	63	45	31	21	14
$T_a = 45^\circ\text{C}$	250	212	169	132	101	75	55	40	28	19	13	8
$T_a = 50^\circ\text{C}$	165	134	107	83	63	48	35	25	18	12	8	
$T_a = 55^\circ\text{C}$	104	85	67	52	40	30	22	16	11	7		
$T_a = 60^\circ\text{C}$	66	53	42	33	25	19	14	10	7			
$T_a = 65^\circ\text{C}$	41	34	27	21	16	12	8					
$T_a = 70^\circ\text{C}$	26	21	17	13	10	7						
$T_a = 75^\circ\text{C}$	16	13	10	8								
$T_a = 80^\circ\text{C}$	10	8										
$T_a = 85^\circ\text{C}$	6											

khrs Max. value limited to 250 000 hours.

> Life Time Graph · Brauchbarkeitsdauer – Diagramm

Useful life depending on ambient temperature T_a and ripple current operating conditions I_r versus rated ripple current at the upper category temperature $I_{r, 85^\circ\text{C}, 120\text{Hz}}$

Brauchbarkeitsdauer in Abhängigkeit von Umgebungstemperatur T_a und Wechselstrombelastung I_r im Verhältnis zur max. Wechselstrombelastung bei oberer Kategorie-temperatur $I_{r, 85^\circ\text{C}, 120\text{Hz}}$

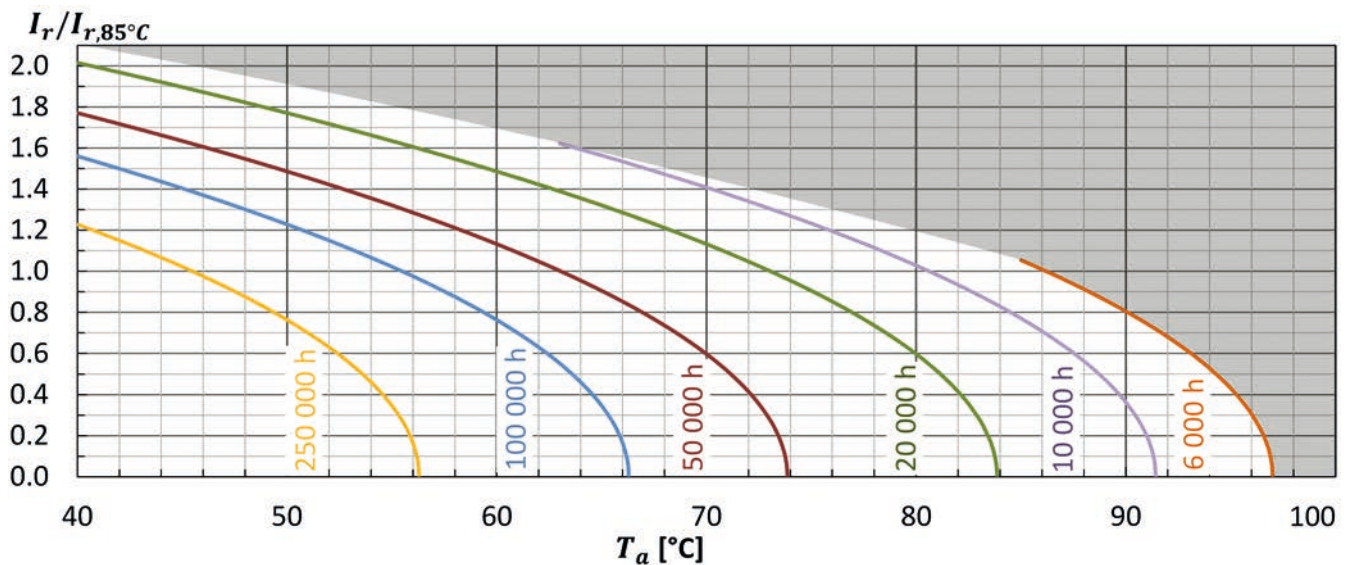

> Life Time Tests and Requirements · Anforderungen Brauchbarkeitsdauer

Life time test	Test procedure	End of Life criteria
Endurance test	$T_a = 85^\circ\text{C}$; V_r, I_r applied 4000 hours	$\Delta C/C \leq 10\%$ (of initial value) $\text{Tan}\delta \leq 175\%$ (of specified value) $I_L \leq$ specified value
Useful life	$T_a = 85^\circ\text{C}$; V_r, I_r applied 6000 hours	$\Delta C/C \leq 15\%$ (of initial value) $\text{Tan}\delta < 200\%$ (of specified value) $I_L \leq$ specified value

Reference Specification: JIS C 5101-4, JIS C 5102, IEC 60384-4