

# VFLR · Screw-Terminal · 12000 h/85 °C

Long Life · High Ripple Current · Bottom cooling design · Low ESR

## > Specifications · Spezifikationen

Items	Characteristics
Temperature range	-40°C ~ + 85°C
Capacitance tolerance (at 20°C)	Standard +/- 20%, -10/+30% on request
Surge voltage / Ripple voltage	Repetitive max. 30 sec per 6 Minutes / ≤ 70V
Leakage current max. $I_L$ (20°C, 5 min)	0.01 • C • $V_r$ [μA] or 5 mA, which is smaller.
Useful life	12 000 hours at 85°C
Field failure rate	0.5 FIT = 0.5 • 10 <sup>-9</sup> Failures/hour
Reference standards	IEC 60384-4, JIS C 5101-4
Vibration	0.75mm, 10...55Hz, 10g, 3x2h
Outer materials	UL94-V0/UL224-VW1 certified (cap/sleeve)
Sleeve withstanding voltage	4000 Vac/ 1min between terminals bundled and plate*
Product Compliance	RoHS, REACH, Conflict Minerals a.o. – refer to p. 14–15

\* Typical value



## > Shape designation · Formbezeichnung

- additional information on p. 12–13 · Zusatzinformationen auf S. 12–13
- mounting accessories from p. 219 · Montagezubehör ab S. 219

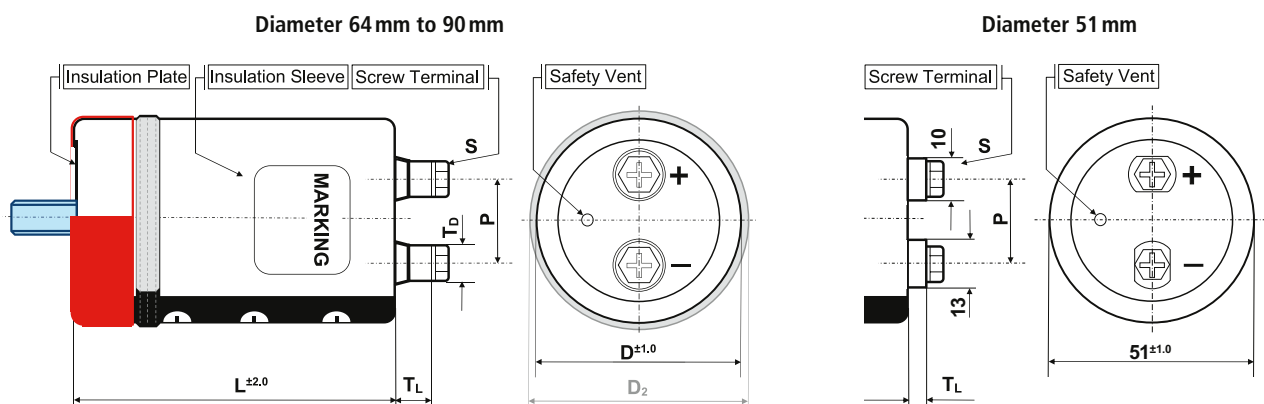

Shape code Features	B Bolt	I/Y double sleeve for 2/3 points metal Bracket	N + suffix WC blank bottom + seating ring	N standard
outer insulation sleeve	•	•	•	•
insulation plate	•	•		•
stud bolt	•			
bottom double sleeve		•		
integrated seating ring			•	

diameter code	ØD	available shape	P	S	T <sub>L</sub>	T <sub>D</sub>	Cap material
C	51	B, N, I, Y	22.0	M5x10	4.5	13/10	PH
D	64	B, N, I, Y	28.6	M5x10	8.0	11	PH
E	77	B, N, I, Y, WC	31.5	M6x12	9.0	12	PH
F	90	B, N, I, Y, WC	31.5	M6x12	8.0	12	PH

Size in mm

## > Product Code · Bestellbezeichnung

**Example:** Series VFLR · 12000 µF +/- 20 % · 400 V · D=90 mm · L= 167 mm with Y-Bracket

<b>VFLR</b>	<b>2G</b>	<b>123</b>	<b>Y</b>	<b>F</b>	<b>167</b>
Series name	Capacitance code	Shape code	Diameter code	Capacitance tolerance	Specific features
Rated voltage code					
Code	Voltage	Code	Voltage		
2V	350	2W	450		
2G	400	2H	500		

∅ : ± 20 %  
Q : -10 % ~ +30 %

Case length code – length in mm (3 digits)

Rated Voltage Code (Surge Voltage) $V_r$ [V DC]	Capacitance $C_r$ [µF]	Ripple Current at 85°C/120Hz $I_r$ [A RMS]	Ripple Current at 40°C/120Hz [A RMS]	ESR (typ) at 20°C/100Hz [mΩ]	Zmax at 20°C/10kHz [mΩ]	ESL (typ) [nH]	Dissipation Factor at 20°C/120Hz $\tan \delta$	DxL [mm]	Product Code # = variable value, see fixing code in the product code
350 VDC Code: 2V  Surge Voltage 400 VDC	2 700	11.0	23.1	20	21	17	0.20	51x96	VFLR2V272#C096
		11.4	24.0	20	21	17	0.20	51x109	VFLR2V272#C109
	3 300	12.2	25.6	16	17	17	0.20	51x109	VFLR2V332#C109
		13.3	27.9	14	16	17	0.20	51x125	VFLR2V392#C125
	3 900	17.0	35.7	14	16	18	0.20	64x107	VFLR2V392#D107
		18.9	39.7	11	12	18	0.20	64x107	VFLR2V472#D107
	5 600	20.8	43.7	10	11	18	0.20	64x123	VFLR2V562#D123
		23.5	49.4	10	11	20	0.20	77x108	VFLR2V562#E108
	6 800	23.1	48.5	8	9	18	0.20	64x147	VFLR2V682#D147
		26.2	55.0	8	9	20	0.20	77x108	VFLR2V682#E108
	8 200	25.4	53.3	7	8	18	0.20	64x164	VFLR2V822#D164
		28.7	60.3	7	8	20	0.20	77x124	VFLR2V822#E124
		32.6	68.5	7	8	20	0.20	90x110	VFLR2V822#F110
	10 000	28.5	59.9	5	6	18	0.20	64x187	VFLR2V103#D187
		31.7	66.6	5	6	20	0.20	77x148	VFLR2V103#E148
		36.0	75.6	5	6	20	0.20	90x110	VFLR2V103#F110
	12 000	34.8	73.1	5	5	20	0.20	77x165	VFLR2V123#E165
		39.3	82.5	5	5	20	0.20	90x126	VFLR2V123#F126
		39.3	82.5	4	4	20	0.20	77x188	VFLR2V153#E188
	15 000	43.6	91.6	4	4	20	0.20	90x150	VFLR2V153#F150
47.3		99.3	3	4	20	0.20	90x167	VFLR2V183#F167	
22 000	52.0	109.2*	3	4	20	0.20	90x190	VFLR2V223#F190	
27 000	56.0	117.6*	2	3	20	0.20	90x268	VFLR2V273#F268	
33 000	57.7	121.2*	2	3	20	0.20	90x268	VFLR2V333#F268	
400 VDC Code: 2G  Surge Voltage 450 VDC	1 800	9.5	20.0	30	31	17	0.20	51x96	VFLR2G182#C096
	2 200	10.2	21.4	25	26	17	0.20	51x96	VFLR2G222#C096
	2 700	11.4	23.9	20	21	17	0.20	51x109	VFLR2G272#C109
	3 300	12.7	26.7	16	17	17	0.20	51x125	VFLR2G332#C125
		15.7	33.0	16	17	18	0.20	64x107	VFLR2G332#D107
3 900	17.2	36.1	14	15	18	0.20	64x107	VFLR2G392#D107	

Additional designs on request · Weitere Designs auf Anfrage

Rated VoltageCode (Surge Voltage) $V_r$ [V DC]	Capacitance $C_r$ [ $\mu$ F]	Ripple Current at 85°C/120Hz $I_r$ [A RMS]	Ripple Current at 40°C/120Hz [A RMS]	ESR (typ) at 20°C/100Hz [m $\Omega$ ]	Zmax at 20°C/10kHz [m $\Omega$ ]	ESL (typ) [nH]	Dissipation Factor at 20°C/120Hz Tan $\delta$	DxL [mm]	Product Code  # = variable value, see fixing code in the product code
<b>400 VDC</b> Code: 2G  Surge Voltage 450 VDC	<b>4 700</b>	19.0	39.9	11	12	18	0.20	64x123	VFLR2G472#D123
		21.5	45.2	11	12	20	0.20	77x108	VFLR2G472#E108
	<b>5 600</b>	20.9	43.9	10	11	18	0.20	64x147	VFLR2G562#D147
		21.1	44.3	10	11	20	0.20	77x95	VFLR2G562#E095
		24.0	50.4	10	11	20	0.20	77x124	VFLR2G562#E124
	<b>6 800</b>	23.2	48.7	8	10	18	0.20	64x164	VFLR2G682#D164
		26.4	55.4	8	10	20	0.20	77x124	VFLR2G682#E124
		29.7	62.4	8	10	20	0.20	90x110	VFLR2G682#F110
	<b>8 200</b>	25.8	54.2	7	7	18	0.20	64x187	VFLR2G822#D187
		28.7	60.3	7	7	20	0.20	77x148	VFLR2G822#E148
		32.6	68.5	7	7	20	0.20	90x110	VFLR2G822#F110
	<b>10 000</b>	31.8	66.8	5	6	20	0.20	77x165	VFLR2G103#E165
		35.9	75.4	5	6	20	0.20	90x126	VFLR2G103#F126
	<b>12 000</b>	35.1	73.7	5	5	20	0.20	77x188	VFLR2G123#E188
		39.0	81.9	5	5	20	0.20	90x150	VFLR2G123#F150
	<b>15 000</b>	43.2	90.7	4	4	20	0.20	90x167	VFLR2G153#F167
	<b>18 000</b>	47.0	98.7	4	4	20	0.20	90x190	VFLR2G183#F190
	<b>22 000</b>	50.5	106.1*	3	3	20	0.20	90x268	VFLR2G223#F268
<b>27 000</b>	52.0	109.2*	2	3	20	0.20	90x268	VFLR2G273#F268	
<b>450 VDC</b> Code: 2W  Surge Voltage 500 VDC	<b>1 500</b>	9.0	18.9	35	37	17	0.20	51x96	VFLR2W152#C096
	<b>1 800</b>	10.1	21.3	30	32	17	0.20	51x109	VFLR2W182#C109
	<b>2 200</b>	11.3	23.8	24	26	17	0.20	51x125	VFLR2W222#C125
	<b>2 700</b>	14.5	30.5	20	23	18	0.20	64x107	VFLR2W272#D107
	<b>3 300</b>	16.5	34.7	16	19	18	0.20	64x123	VFLR2W332#D123
	<b>3 900</b>	17.8	37.4	14	15	18	0.20	64x123	VFLR2W392#D123
		20.1	42.2	14	15	20	0.20	77x108	VFLR2W392#E108
	<b>4 700</b>	19.6	41.2	11	12	18	0.20	64x147	VFLR2W472#D147
		22.3	46.8	11	12	20	0.20	77x108	VFLR2W472#E108
		21.6	45.4	10	11	18	0.20	64x164	VFLR2W562#D164
	<b>5 600</b>	24.3	51.0	10	11	20	0.20	77x124	VFLR2W562#E124
		27.6	58.0	10	11	20	0.20	90x110	VFLR2W562#F110
		22.9	48.1	5	6	18	0.20	64x187	VFLR2W682#D187
	<b>6 800</b>	26.8	56.3	5	6	20	0.20	77x148	VFLR2W682#E148
		30.4	63.8	5	6	20	0.20	90x110	VFLR2W682#F110
		29.9	62.8	7	8	20	0.20	77x188	VFLR2W822#E188
	<b>8 200</b>	33.4	70.1	7	8	20	0.20	90x126	VFLR2W822#F126
		34.1	71.6	5	7	20	0.20	77x228	VFLR2W103#E228
	<b>10 000</b>	36.5	76.7	5	7	20	0.20	90x150	VFLR2W103#F150
		36.2	76.0	5	7	20	0.20	90x167	VFLR2W103#F167
39.4		82.7	5	5	20	0.20	90x190	VFLR2W123#F190	
<b>13 000</b>	41.0	86.1	5	5	20	0.20	90x190	VFLR2W133#F190	
<b>15 000</b>	43.3	90.9	4	5	20	0.20	90x230	VFLR2W153#F230	
<b>18 000</b>	46.9	98.5	3	4	20	0.20	90x268	VFLR2W183#F268	

Additional designs on request · Weitere Designs auf Anfrage

# VFLR · Screw-Terminal · 12000 h/85 °C

Rated VoltageCode (Surge Voltage) $V_r$ [V DC]	Capacitance $C_r$ [μF]	Ripple Current at 85°C/120Hz $I_r$ [A RMS]	Ripple Current at 40°C/120Hz [A RMS]	ESR (typ) at 20°C/100Hz [mΩ]	Zmax at 20°C/10kHz [mΩ]	ESL (typ) [nH]	Dissipation Factor at 20°C/120Hz Tan δ	DxL [mm]	Product Code  # = variable value, see fixing code in the product code
<b>500 VDC</b> Code: 2H  Surge Voltage 550 VDC	820	6.1	12.9	71	74	17	0.20	51x96	VFLR2H821#C096
	1 000	7.2	15.1	58	61	17	0.20	51x96	VFLR2H102#C096
	1 200	8.0	16.8	48	51	17	0.20	51x109	VFLR2H122#C109
	1 500	9.2	19.3	38	41	17	0.20	51x125	VFLR2H152#C125
	1 800	11.3	23.7	32	35	18	0.20	64x107	VFLR2H182#D107
	2 200	12.6	26.5	26	28	18	0.20	64x107	VFLR2H222#D107
	2 700	14.0	29.4	22	24	18	0.20	64x123	VFLR2H272#D123
		15.9	33.4	22	24	20	0.20	77x108	VFLR2H272#E108
	3 000	14.6	30.7	20	22	18	0.20	64x147	VFLR2H272#D147
	3 300	15.6	32.8	18	19	18	0.20	64x147	VFLR2H332#D147
		17.8	37.4	18	19	20	0.20	77x108	VFLR2H332#E108
	3 900	17.1	35.9	15	16	18	0.20	64x164	VFLR2H392#D164
		19.3	40.5	15	16	20	0.20	77x124	VFLR2H392#E124
		21.9	46.0	15	16	20	0.20	90x110	VFLR2H392#F110
	4 700	19.0	39.9	13	14	18	0.20	64x187	VFLR2H472#D187
		21.2	44.5	13	14	20	0.20	77x148	VFLR2H472#E148
		24.0	50.4	13	14	20	0.20	90x110	VFLR2H472#F110
	5 600	22.8	47.9	11	12	20	0.20	77x148	VFLR2H562#E148
		23.5	49.4	11	12	20	0.20	77x188	VFLR2H562#E188
		26.1	54.8	11	12	20	0.20	90x126	VFLR2H562#F126
	6 800	25.8	54.2	9	10	20	0.20	77x188	VFLR2H682#E188
		28.6	60.1	9	10	20	0.20	90x150	VFLR2H682#F150
	8 200	31.1	65.3	5	6	20	0.20	90x167	VFLR2H822#F167
	10 000	34.2	71.8	5	6	20	0.20	90x190	VFLR2H103#F190
12 000	36.3	76.2	4	5	20	0.20	90x268	VFLR2H123#F268	
14 000	38.3	80.4	3	3	20	0.20	90x268	VFLR2H143#F268R	
15 000	37.8	79.4	3	3	20	0.20	90x268	VFLR2H153#F268	

\* Please contact us if load condition exceeds terminals related  $I_{rmax}$  referred on page 13

Additional designs on request · Weitere Designs auf Anfrage

## > Ripple Current Multiplier · Wechselstrommultiplikator

Frequency [Hz]	50/60	120	300	1k	≥ 10k
Multiplier	0.80	1.00	1.18	1.34	1.45

Ta (°C)	40	45	50	55	60	65	70	75	80	85
Multiplier	2.1	2.1	2.0	1.9	1.8	1.6	1.5	1.3	1.1	1.0

Forced cooling – Wind speed [m/sec]	v < 0.25	v ≥ 0.25	v ≥ 0.5	v ≥ 1.0	v ≥ 2.0	v ≥ 3.0
Multiplier	1.00	1.07	1.15	1.25	1.30	1.35

Water cooled heatsink – size ratio [L/D]	1.10	1.25	1.40	1.55	1.70	2.00	2.50	3.00
Multiplier	2.0	1.9	1.7	1.6	1.5	1.4	1.2	1.1

> Life Time Table · Brauchbarkeitsdauer – Tabelle

VFLR	Useful life as function of ambient temperature and ripple current												
	$I_r$ at 85°C	x 1.0	x 1.1	x 1.2	x 1.3	x 1.4	x 1.5	x 1.6	x 1.7	x 1.8	x 1.9	x 2.0	x 2.1
$T_a = 40°C$	250	250	250	250	250	240	176	127	90	62	42	28	
$T_a = 45°C$	250	250	250	250	202	151	111	80	57	39	26	17	
$T_a = 50°C$	250	250	214	167	127	96	70	50	36	25	16		
$T_a = 55°C$	209	170	135	105	80	60	44	32	22	15			
$T_a = 60°C$	132	107	85	66	51	38	28	20	14				
$T_a = 65°C$	83	68	54	42	32	24	17						
$T_a = 70°C$	52	43	34	26	20	15							
$T_a = 75°C$	33	27	21	16									
$T_a = 80°C$	21	17											
$T_a = 85°C$	12												

khrs      Max. value limited to 250 000 hours.

> Life Time Graph · Brauchbarkeitsdauer – Diagramm

Useful life depending on ambient temperature  $T_a$  and ripple current operating conditions  $I_r$  versus rated ripple current at the upper category temperature  $I_{r, 85°C, 120Hz}$

Brauchbarkeitsdauer in Abhängigkeit von Umgebungstemperatur  $T_a$  und Wechselstrombelastung  $I_r$  im Verhältnis zur max. Wechselstrombelastung bei oberer Kategorie-temperatur  $I_{r, 85°C, 120Hz}$

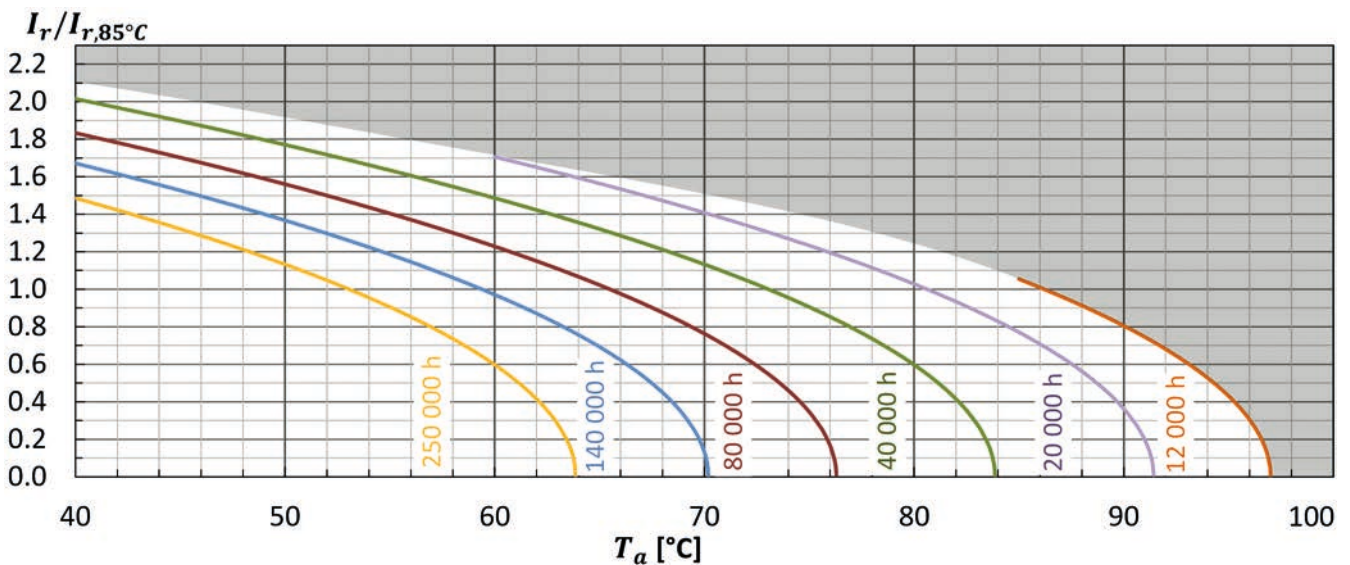

> Life Time Tests and Requirements · Anforderungen Brauchbarkeitsdauer

Life time test	Test procedure	End of Life criteria
Endurance test	$T_a = 85°C$ ; $V_r$ , $I_r$ applied 8000 hours	$\Delta C/C \leq 10\%$ (of initial value) $Tan\delta \leq 175\%$ (of specified value) $I_L \leq$ specified value
Useful life	$T_a = 85°C$ ; $V_r$ , $I_r$ applied 12000 hours	$\Delta C/C \leq 15\%$ (of initial value) $Tan\delta < 200\%$ (of specified value) $I_L \leq$ specified value

Reference Specification: JIS C 5101-4, JIS C 5102, IEC 60384-4