

# VF · Screw-Terminal · 6000 h/85 °C

## Standard Performances · Bottom cooling design · Smaller Size

Optional design for permanent and deep charge-discharge application with high voltage hub and pulsed operation mode upon request.

Spezielles Design für häufige und tiefe Lade-, Entladeanwendungen mit hohem Spannungshub und Impulsbetrieb auf Anfrage erhältlich.

### > Specifications · Spezifikationen

Items	Characteristics
Temperature range	-40°C ~ +85°C (650 VDC: -25°C ~ +85°C)
Capacitance tolerance (at 20°C)	Standard +/- 20%, -10/+30% on request
Surge voltage / Ripple voltage	Repetitive max. 30 sec per 6 Minutes / ≤ 50V
Leakage current max. I <sub>L</sub> (20°C, 5 min)	0.01 • C • V, [μA] or 5 mA, which is smaller.
Useful life	6000 hours at 85°C
Field failure rate	0.5 FIT = 0.5 • 10 <sup>-9</sup> Failures/hour
Reference standards	IEC 60384-4, JIS C 5101-4
Vibration	0.75mm, 10...55Hz, 10g, 3x2h
Outer materials	UL94-V0/UL224-VW1 certified (cap/sleeve)
Sleeve withstanding voltage	4000 Vac/1min between terminals bundled and plate*
Product Compliance	RoHS, REACH, Conflict Minerals a.o. – refer to p. 12–13

\* Typical value



### > Shape designation · Formbezeichnung

- additional information on p. 10–11 · Zusatzinformationen auf S. 10–11
- mounting accessories from p. 189 · Montagezubehör ab S. 189

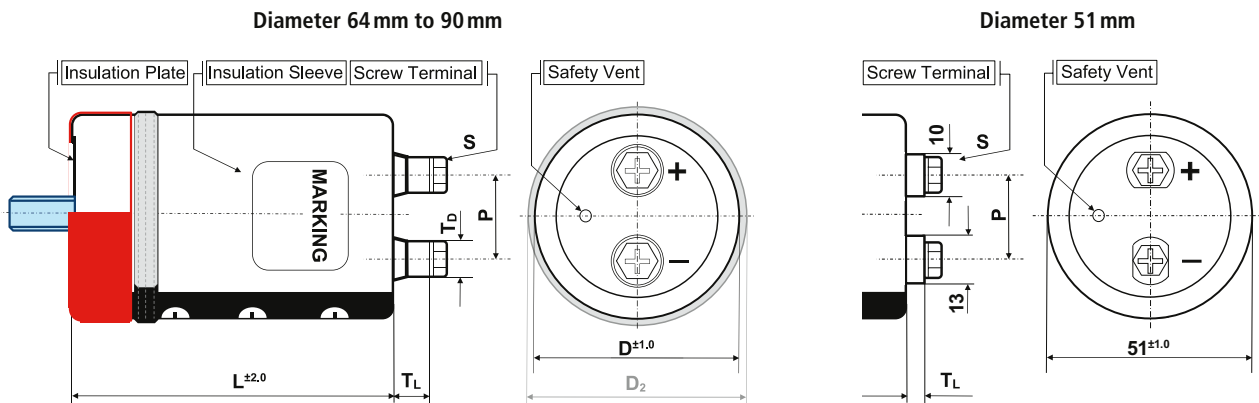

Shape code Features	B Bolt	I/Y double sleeve for 2/3 points metal Bracket	N + suffix WC blank bottom + seating ring	N standard
outer insulation sleeve	•	•	•	•
insulation plate	•	•		•
stud bolt	•			
bottom double sleeve		•		
integrated seating ring			•	

diameter code	ØD	available shape	P	S	T <sub>L</sub>	T <sub>D</sub>	Cap material
C	51	B, N, I, Y	22.0	M5x10	4.5	13/10	PH
D	64	B, N, I, Y	28.6	M5x10	8.0	11	PH
E	77	B, N, I, Y, WC	31.5	M5x10	8.0	11	PH
				M6x12	9.0	12	PH
F	90	B, N, I, Y, WC	31.5	M5x10	7.0	11	PH
				M6x12	8.0	12	PH

Size in mm. First listed terminal is standard.

> Product Code · Bestellbezeichnung

**Example:** Series VF · 12000 µF +/- 20 % · 400 V · D=90 mm · L= 126 mm with 3 points-Bracket

<b>VF</b>	<b>2G</b>	<b>123</b>	<b>Y</b>	<b>F</b>	<b>126</b>
Series name	Capacitance code	Shape code	Diameter code	Capacitance tolerance	Specific features (e.g. M6 ...)
Rated voltage code					
Code	Voltage	Code	Voltage	Code	Voltage
0J	6.3	1H	50	2D	200
1A	10	1J	63	2E	250
1C	16	1K	80	2V	350
1E	25	2A	100	2G	400
1V	35	2C	160	2W	450

Capacitance tolerance  
 Ø : ± 20 %  
 Q : -10 % ~ +30 %

Case length code – length in mm (3 digits)

Rated Voltage Code (Surge Voltage) V <sub>r</sub> [V DC]	Capacitance C <sub>r</sub> [µF]	Ripple Current at 85°C/120Hz I <sub>r</sub> [A RMS]	Ripple Current at 40°C/120Hz [A RMS]	ESR (typ) at 20°C/100Hz [mΩ]	Z <sub>max</sub> at 20°C/10kHz [mΩ]	ESL (typ) [nH]	Dissipation Factor at 20°C/120Hz Tan δ	DxL [mm]	Product Code # = variable value, see fixing code in the product code
<b>6.3 VDC</b> Code: 0J  Surge Voltage 10 VDC	330 000	16.1	43.5	8	9	18	1.50	64x94	VF0J334#D094
	470 000	18.6	50.2	7	8	18	1.80	64x107	VF0J474#D107
	560 000	19.7	53.2	6	7	18	2.40	64x123	VF0J564#D123
		18.3	49.4	6	7	20	2.40	77x95	VF0J664#E095
	680 000	20.1	54.3	5	7	20	2.90	77x108	VF0J684#E108
<b>10 VDC</b> Code: 1A  Surge Voltage 16 VDC	330 000	17.2	46.4	5	6	18	1.80	64x94	VF1A334#D094
	390 000	18.7	50.5	4	6	18	2.00	64x107	VF1A394#D107
		21.1	57.0	4	6	18	2.30	64x123	VF1A474#D123
	470 000	19.4	52.4	4	6	20	2.30	77x95	VF1A474#E095
		21.0	56.7	3	5	20	3.00	77x108	VF1A564#E108
	680 000	23.8	64.3	3	5	20	3.70	77x124	VF1A684#E124
<b>16 VDC</b> Code: 1C  Surge Voltage 25 VDC	270 000	16.2	43.7	4	6	18	1.60	64x94	VF1C274#D094
		18.3	49.4	4	6	18	1.80	64x123	VF1C334#D123
	330 000	18.0	48.6	4	6	20	1.80	77x95	VF1C334#E095
		19.5	52.7	4	5	20	2.40	77x108	VF1C394#E108
	470 000	22.0	59.4	3	5	20	2.90	77x124	VF1C474#E124
		21.9	59.1	3	5	20	2.90	90x97	VF1C474#F097
	560 000	23.7	64.0	3	5	20	3.20	90x110	VF1C564#F110
<b>25 VDC</b> Code: 1E  Surge Voltage 32 VDC	180 000	13.7	37.0	5	6	18	1.20	64x94	VF1E184#D094
	220 000	15.1	40.8	4	5	18	1.20	64x107	VF1E224#D107
	270 000	17.2	46.4	4	5	18	1.40	64x123	VF1E274#D123
	330 000	19.2	51.8	4	5	20	1.40	77x95	VF1E334#E095
		20.8	56.2	4	5	20	2.10	77x108	VF1E394#E108
	470 000	23.4	63.2	3	5	20	2.30	77x124	VF1E474#E124
		22.9	61.8	3	5	20	2.30	90x97	VF1E474#F097
560 000	24.8	67.0	3	4	20	2.30	90x110	VF1E564#F110	
<b>35 VDC</b> Code: 1V  Surge Voltage 44 VDC	120 000	12.9	34.8	5	7	18	1.00	64x94	VF1V124#D094
	150 000	14.4	38.9	5	7	18	1.00	64x107	VF1V154#D107
		16.3	44.0	5	7	18	1.00	64x123	VF1V184#D123
	180 000	15.2	41.0	5	7	20	1.00	77x95	VF1V184#E095

Additional designs on request · Weitere Designs auf Anfrage

# VF · Screw-Terminal · 6000 h/85 °C

Rated VoltageCode (Surge Voltage) $V_r$ [V DC]	Capacitance $C_r$ [ $\mu$ F]	Ripple Current at 85°C/120Hz $I_r$ [A RMS]	Ripple Current at 40°C/120Hz [A RMS]	ESR (typ) at 20°C/100Hz [m $\Omega$ ]	Zmax at 20°C/10kHz [m $\Omega$ ]	ESL (typ) [nH]	Dissipation Factor at 20°C/120Hz Tan $\delta$	DxL [mm]	Product Code  # = variable value, see fixing code in the product code
<b>35 VDC</b> Code: 1V Surge Voltage 44 VDC	220 000	16.8	45.4	5	7	20	1.20	77x108	VF1V224#E108
	270 000	19.0	51.3	4	6	20	1.20	77x124	VF1V274#E124
		18.8	50.8	4	6	20	1.20	90x97	VF1V274#F097
		20.7	55.9	4	6	20	1.80	90x110	VF1V334#F110
<b>50 VDC</b> Code: 1H Surge Voltage 63 VDC	82 000	12.1	32.7	7	8	18	0.70	64x94	VF1H823#D094
	100 000	13.4	36.2	6	7	18	0.70	64x107	VF1H104#D107
	150 000	16.8	45.4	5	7	18	0.90	64x123	VF1H154#D123
		13.9	37.5	5	7	20	0.90	77x95	VF1H154#E095
	180 000	15.2	41.0	5	6	20	1.40	77x108	VF1H184#E108
	220 000	17.2	46.4	4	6	20	1.50	77x124	VF1H224#E124
		16.5	44.6	4	6	20	1.50	90x97	VF1H224#F097
270 000	18.2	49.1	3	5	20	1.50	90x110	VF1H274#F110	
<b>63 VDC</b> Code: 1J Surge Voltage 80 VDC	56 000	13.3	35.9	8	9	18	0.50	64x94	VF1J563#D094
	68 000	14.6	39.4	7	8	18	0.50	64x107	VF1J683#D107
	82 000	16.5	44.6	7	8	18	0.70	64x123	VF1J823#D123
	100 000	15.5	41.9	7	8	20	0.70	77x95	VF1J104#E095
	120 000	16.9	45.6	6	7	20	1.10	77x108	VF1J124#E108
		19.3	52.1	6	7	20	1.20	77x124	VF1J154#E124
	150 000	18.3	49.4	6	7	20	1.20	90x97	VF1J154#F097
180 000	19.9	53.7	5	6	20	1.20	90x110	VF1J184#F110	
<b>80 VDC</b> Code: 1K Surge Voltage 100 VDC	39 000	12.8	34.6	6	7	18	0.35	64x94	VF1K393#D094
	47 000	14.0	37.8	6	7	18	0.35	64x107	VF1K473#D107
	56 000	15.7	42.4	5	7	18	0.40	64x123	VF1K563#D123
		15.3	41.3	5	7	20	0.40	77x95	VF1K563#E095
	68 000	16.8	45.4	4	7	20	0.40	77x108	VF1K683#E108
	82 000	18.9	51.0	3	6	20	0.60	77x124	VF1K823#E124
		18.1	48.9	3	6	20	0.60	90x97	VF1K823#F097
100 000	19.8	53.5	3	6	20	0.70	90x110	VF1K104#F110	
<b>100 VDC</b> Code: 2A Surge Voltage 125 VDC	22 000	9.6	25.9	8	9	18	0.20	64x94	VF2A223#D094
	33 000	11.7	31.6	6	7	18	0.25	64x107	VF2A333#D107
	39 000	13.1	35.4	5	7	18	0.30	64x123	VF2A393#D123
		12.8	34.6	5	7	20	0.30	77x95	VF2A393#E095
	47 000	14.0	37.8	5	7	20	0.30	77x108	VF2A473#E108
	56 000	15.6	42.1	4	6	20	0.45	77x124	VF2A563#E124
		15.8	42.7	4	6	20	0.45	90x97	VF2A563#F097
	68 000	17.3	46.7	4	6	20	0.50	90x110	VF2A683#F110
	100 000	20.9	56.4	3	5	20	0.45	77x165	VF2A104#E165
22.9		61.8	3	5	20	0.45	90x190	VF2A104#F190	
<b>160 VDC</b> Code: 2C Surge Voltage 200 VDC	12 000	12.3	33.2	12	15	18	0.25	64x94	VF2C123#D094
	15 000	13.7	37.0	11	12	18	0.25	64x107	VF2C153#D107
		15.8	42.7	11	12	18	0.25	77x95	VF2C153#E095
	18 000	15.4	41.6	9	11	18	0.25	64x123	VF2C183#D123
		17.4	47.0	9	11	20	0.25	77x95	VF2C183#E095
	22 000	16.8	45.4	8	8	18	0.25	64x147	VF2C223#D147
	19.1	51.6	8	8	20	0.25	77x108	VF2C223#E108	

Additional designs on request · Weitere Designs auf Anfrage

Rated VoltageCode (Surge Voltage) $V_r$ [V DC]	Capacitance $C_r$ [ $\mu$ F]	Ripple Current at 85°C/120Hz $I_r$ [A RMS]	Ripple Current at 40°C/120Hz [A RMS]	ESR (typ) at 20°C/100Hz [m $\Omega$ ]	Zmax at 20°C/10kHz [m $\Omega$ ]	ESL (typ) [nH]	Dissipation Factor at 20°C/120Hz Tan $\delta$	DxL [mm]	Product Code  # = variable value, see fixing code in the product code
<b>160 VDC</b> Code: 2C  Surge Voltage 200 VDC	27 000	21.7	58.6	7	8	20	0.25	77x124	VF2C273#E124
		24.6	66.4	7	8	20	0.25	90x97	VF2C273#F097
	33 000	23.5	63.5	6	7	20	0.25	77x148	VF2C333#E148
		27.0	72.9	6	7	20	0.25	90x110	VF2C333#F110
39 000	29.1	78.6	5	7	20	0.25	90x126	VF2C393#F126	
<b>200 VDC</b> Code: 2D  Surge Voltage 250 VDC	12 000	12.3	33.2	12	14	18	0.25	64x94	VF2D123#D094
	15 000	14.1	38.1	10	13	18	0.25	64x123	VF2D153#D123
		15.8	42.7	10	13	20	0.25	77x95	VF2D153#E095
	18 000	15.2	41.0	8	12	18	0.25	64x147	VF2D183#D147
		17.3	46.7	8	12	20	0.25	77x108	VF2D183#E108
	22 000	19.6	52.9	7	7	20	0.25	77x124	VF2D223#E124
		22.2	59.9	7	7	20	0.25	90x97	VF2D223#F097
	27 000	21.3	57.5	6	7	20	0.25	77x148	VF2D273#E148
		24.4	65.9	6	7	20	0.25	90x110	VF2D273#F110
	33 000	26.7	72.1	5	7	20	0.25	90x126	VF2D333#F126
35 000	24.7	66.7	5	7	20	0.25	77x165	VF2D353#E165	
43 000	30.4	82.1	4	6	20	0.25	90x150	VF2D433#F150	
<b>250 VDC</b> Code: 2E  Surge Voltage 300 VDC	8 200	10.2	27.5	15	16	18	0.25	64x94	VF2E822#D94
	10 000	11.5	31.1	12	14	18	0.25	64x123	VF2E103#D123
	12 000	12.4	33.5	10	11	18	0.25	64x147	VF2E123#D147
		14.2	38.3	10	11	20	0.25	77x95	VF2E123#E095
	15 000	16.2	43.7	8	11	20	0.25	77x124	VF2E153#E124
		18.3	49.4	8	11	20	0.25	90x97	VF2E153#F097
	18 000	17.4	47.0	7	10	20	0.25	77x148	VF2E183#E148
		19.9	53.7	7	10	20	0.25	90x110	VF2E183#F110
22 000	21.8	58.9	6	8	20	0.25	90x126	VF2E223#F126	
26 000	23.6	63.7	5	6	20	0.25	90x150	VF2E263#F150	
<b>350 VDC</b> Code: 2V  Surge Voltage 400 VDC	1 800	7.4	15.6	55	58	17	0.20	51x75	VF2V182#C075
	2 200	8.5	17.9	45	47	17	0.20	51x96	VF2V222#C096
	2 700	9.8	20.6	37	39	17	0.20	51x109	VF2V272#C109
	3 300	11.2	23.6	30	32	17	0.20	51x125	VF2V332#C125
		12.6	26.5	30	32	17	0.20	64x94	VF2V332#D094
	4 700	15.1	31.7	21	22	18	0.20	64x94	VF2V472#D094
		16.4	34.4	18	19	18	0.20	64x107	VF2V562#D107
	6 800	18.6	39.1	15	15	18	0.20	64x123	VF2V682#D123
		20.9	43.9	15	15	20	0.20	77x95	VF2V682#E095
	8 200	20.1	42.2	12	15	18	0.20	64x147	VF2V822#D147
		22.9	48.1	12	15	20	0.20	77x108	VF2V822#E108
	10 000	22.9	48.1	10	15	18	0.20	64x187	VF2V103#D187
		25.9	54.4	10	15	20	0.20	77x124	VF2V103#E124
		29.3	61.5	10	15	20	0.20	90x97	VF2V103#F097
	12 000	27.8	58.4	8	13	20	0.20	77x148	VF2V123#E148
		31.7	66.6	8	13	20	0.20	90x126	VF2V123#F126
15 000	31.9	67.0	7	10	20	0.20	77x188	VF2V153#E188	
	35.2	73.9	7	10	20	0.20	90x150	VF2V153#F150	

Additional designs on request · Weitere Designs auf Anfrage

# VF · Screw-Terminal · 6000 h/85 °C

Rated VoltageCode (Surge Voltage) $V_r$ [V DC]	Capacitance $C_r$ [μF]	Ripple Current at 85°C/120Hz $I_r$ [A RMS]	Ripple Current at 40°C/120Hz [A RMS]	ESR (typ) at 20°C/100Hz [mΩ]	Zmax at 20°C/10kHz [mΩ]	ESL (typ) [nH]	Dissipation Factor at 20°C/120Hz Tan δ	DxL [mm]	Product Code  # = variable value, see fixing code in the product code
<b>350 VDC</b> Code: 2V  Surge Voltage 400 VDC	18 000	36.0	75.6	7	10	20	0.20	77x228	VF2V183#E228
		37.9	79.6	7	10	20	0.20	90x167	VF2V183#F167
	22 000	41.1	86.3	6	9	20	0.20	90x230	VF2V223#F230
	26 000	47.1	98.9	5	7	20	0.20	90x230	VF2V263#F230
	27 000	44.9	94.3	5	7	20	0.20	90x268	VF2V273#F268
	30 000	47.9	100.6	4	6	20	0.20	90x230	VF2V303#F230
<b>400 VDC</b> Code: 2G  Surge Voltage 450 VDC	1 500	6.8	14.3	68	73	17	0.20	51x75	VF2G152#C075
	2 200	8.5	17.9	47	50	17	0.20	51x96	VF2G222#C096
	2 700	9.8	20.6	38	41	17	0.20	51x109	VF2G272#C109
	3 300	11.2	23.4	31	34	17	0.20	51x125	VF2G332#C125
		13.7	28.8	26	28	18	0.20	64x94	VF2G392#D094
	4 700	15.0	31.5	21	22	18	0.20	64x107	VF2G472#D107
		17.4	36.5	21	22	20	0.20	77x95	VF2G472#E095
	5 600	16.9	35.5	18	19	18	0.20	64x123	VF2G562#D123
		19.0	39.9	18	19	20	0.20	77x95	VF2G562#E095
	6 800	18.3	38.4	15	15	18	0.20	64x147	VF2G682#D147
		20.8	43.7	15	15	20	0.20	77x108	VF2G682#E108
	8 200	20.8	43.7	12	15	18	0.20	64x187	VF2G822#D187
		23.5	49.4	12	15	20	0.20	77x124	VF2G822#E124
		26.6	55.9	12	15	20	0.20	90x97	VF2G822#F097
	10 000	25.4	53.3	10	15	20	0.20	77x148	VF2G103#E148
		29.1	61.1	10	15	20	0.20	90x110	VF2G103#F110
	12 000	28.5	59.9	8	13	20	0.20	77x188	VF2G123#E188
		31.7	66.6	8	13	20	0.20	90x126	VF2G123#F126
	15 000	32.9	69.1	8	10	20	0.20	77x228	VF2G153#E228
		34.6	72.7	8	10	20	0.20	90x167	VF2G153#F167
	18 000	38.6	81.1	6	9	20	0.20	90x150	VF2G183#F150
		38.2	80.2	6	9	20	0.20	90x190	VF2G183#F190
	20 000	37.9	79.6	6	9	20	0.20	77x228	VF2G203#E228
	22 000	42.2	88.6	5	7	20	0.20	90x190	VF2G223#F190
41.1		86.3	5	7	20	0.20	90x230	VF2G223#F230	
25 000	43.8	92.0	5	7	20	0.20	90x230	VF2G253#F230	
29 000	47.1	98.9	4	6	20	0.20	90x230	VF2G293#F230S	
34 000	54.4	114.2*	4	6	20	0.20	90x268	VF2G343#F268	
<b>450 VDC</b> Code: 2W  Surge Voltage 500 VDC	1 200	6.3	13.3	86	90	17	0.20	51x75	VF2W122#C075
	1 500	7.5	15.8	69	72	17	0.20	51x96	VF2W152#C096
	1 800	8.4	17.7	57	60	17	0.20	51x109	VF2W182#C109
	2 200	9.4	19.8	47	50	17	0.20	51x125	VF2W222#C125
	2 700	11.7	24.6	38	40	18	0.20	64x94	VF2W272#D094
	3 300	12.9	27.1	30	35	18	0.20	64x107	VF2W332#D107
	3 900	14.5	30.5	27	32	18	0.20	64x123	VF2W392#D123
		16.2	34.0	27	32	20	0.20	77x95	VF2W392#E095
	4 700	17.8	37.4	21	21	20	0.20	77x108	VF2W472#E108
		17.0	35.7	20	20	18	0.20	64x147	VF2W562#D147
	5 600	19.9	41.8	20	20	20	0.20	77x124	VF2W562#E124
		22.5	47.3	20	20	20	0.20	90x97	VF2W562#F097

Additional designs on request · Weitere Designs auf Anfrage

Rated VoltageCode (Surge Voltage) $V_r$ [V DC]	Capacitance $C_r$ [ $\mu$ F]	Ripple Current at 85°C/120Hz $I_r$ [A RMS]	Ripple Current at 40°C/120Hz [A RMS]	ESR (typ) at 20°C/100Hz [m $\Omega$ ]	Zmax at 20°C/10kHz [m $\Omega$ ]	ESL (typ) [nH]	Dissipation Factor at 20°C/120Hz Tan $\delta$	DxL [mm]	Product Code  # = variable value, see fixing code in the product code
<b>450 VDC</b> Code: 2W  Surge Voltage 500 VDC	6 200	20.4	42.8	17	19	20	0.20	77x108	VF2W622#E108
		19.4	40.7	15	18	18	0.20	64x187	VF2W682#D187
	6 800	21.4	44.9	15	18	20	0.20	77x148	VF2W682#E148
		24.6	51.7	15	18	20	0.20	90x110	VF2W682#F110
	8 200	24.0	50.4	14	16	20	0.20	77x165	VF2W822#E165
		26.8	56.3	14	16	20	0.20	90x126	VF2W822#F126
	10 000	26.7	56.1	10	15	20	0.20	77x188	VF2W103#E188
		29.4	61.7	10	15	20	0.20	90x150	VF2W103#F150
	12 000	29.2	61.3	9	12	20	0.15	77x188	VF2W123#E188
		30.2	63.4	9	12	20	0.20	77x228	VF2W123#E228
	15 000	31.7	66.6	9	12	20	0.20	90x167	VF2W123#F167
		35.7	75.0	7	10	20	0.20	90x190	VF2W153#F190
	18 000	38.1	80.0	6	9	20	0.20	90x230	VF2W183#F230
	20 000	40.1	84.2	6	8	20	0.20	90x230	VF2W203#F230
22 000	41.6	87.4	5	7	20	0.20	90x268	VF2W223#F268	
<b>500 VDC</b> Code: 2H  Surge Voltage 550 VDC	820	4.7	9.9	117	110	17	0.20	51x75	VF2H821#C075
	1 000	5.6	11.8	96	90	17	0.20	51x96	VF2H102#C096
	1 200	6.3	13.3	80	75	17	0.20	51x109	VF2H122#C109
	1 500	7.2	15.2	64	60	17	0.20	51x125	VF2H152#C125
	1 800	9.1	19.1	53	50	18	0.20	64x94	VF2H182#D094
	2 200	10.0	21.0	40	35	18	0.20	64x107	VF2H222#D107
		11.4	23.9	37	33	18	0.20	64x123	VF2H272#D123
	2 700	12.9	27.1	37	33	20	0.20	77x95	VF2H272#E095
		12.4	26.0	36	32	18	0.20	64x147	VF2H332#D147
	3 300	14.2	29.8	36	32	20	0.20	77x108	VF2H332#E108
		13.9	29.2	27	29	18	0.20	64x164	VF2H392#D164
	3 900	15.8	33.2	27	29	20	0.20	77x124	VF2H392#E124
		17.9	37.6	27	29	20	0.20	90x97	VF2H392#F097
	4 700	15.4	32.3	25	25	18	0.20	64x187	VF2H472#D187
		17.0	35.7	25	25	20	0.20	77x148	VF2H472#E148
	5 600	19.5	41.0	25	25	20	0.20	90x110	VF2H472#F110
		18.9	39.7	23	21	20	0.20	77x165	VF2H562#E165
	6 800	21.1	44.3	23	21	20	0.20	90x126	VF2H562#F126
		20.9	43.9	20	18	20	0.20	77x188	VF2H682#E188
	8 200	23.1	48.5	20	18	20	0.20	90x150	VF2H682#F150
23.8		50.0	17	16	20	0.20	77x228	VF2H822#E228	
10 000	25.0	52.5	17	16	20	0.20	90x167	VF2H822#F167	
	27.8	58.4	14	16	20	0.20	90x190	VF2H103#F190	
12 000	29.6	62.2	12	14	20	0.20	90x230	VF2H123#F230	
14 000	31.9	67.0	11	12	20	0.20	90x230	VF2H143#F230	
15 000	32.7	68.7	10	12	20	0.20	90x268	VF2H153#F268	
<b>550 VDC</b> Code: 2L Surge Voltage 600 VDC	560	3.9	8.2	200	215	17	0.20	51x75	VF2L561#C075
	680	4.2	8.8	165	177	17	0.20	51x75	VF2L681#C075
	820	5.0	10.5	137	147	17	0.20	51x96	VF2L821#C096
	1 000	5.6	11.8	112	120	17	0.20	51x109	VF2L102#C109

Additional designs on request · Weitere Designs auf Anfrage

# VF · Screw-Terminal · 6000 h/85 °C

Rated VoltageCode (Surge Voltage) $V_r$ [V DC]	Capacitance $C_r$ [ $\mu$ F]	Ripple Current at 85°C/120Hz $I_r$ [A RMS]	Ripple Current at 40°C/120Hz [A RMS]	ESR (typ) at 20°C/100Hz [m $\Omega$ ]	Zmax at 20°C/10kHz [m $\Omega$ ]	ESL (typ) [nH]	Dissipation Factor at 20°C/120Hz Tan $\delta$	DxL [mm]	Product Code  # = variable value, see fixing code in the product code
<b>550 VDC</b> Code: 2L  Surge Voltage 600 VDC	1 200	6.4	13.4	93	100	17	0.20	51x125	VF2L122#C125
		7.2	15.1	93	100	18	0.20	64x94	VF2L122#D094
	1 500	8.1	17.0	74	80	18	0.20	64x94	VF2L152#D094
		8.9	18.7	61	50	18	0.20	64x107	VF2L182#D107
	1 800	10.3	21.6	61	50	20	0.20	77x95	VF2L182#E095
		10.1	21.2	53	50	18	0.20	64x123	VF2L222#D123
	2 200	11.4	23.9	53	50	20	0.20	77x95	VF2L222#E095
		11.0	23.1	40	35	18	0.20	64x147	VF2L272#D147
	2 700	12.5	26.3	40	35	20	0.20	77x108	VF2L272#E108
		14.5	30.5	40	35	20	0.20	90x97	VF2L272#F097
	3 300	12.5	26.3	38	32	18	0.20	64x164	VF2L332#D164
		14.2	29.8	38	32	20	0.20	77x124	VF2L332#E124
	3 900	16.1	33.8	38	32	20	0.20	90x97	VF2L332#F097
		13.7	28.8	30	27	18	0.20	64x187	VF2L392#D187
	4 700	15.4	32.3	30	27	20	0.20	77x124	VF2L392#E124
		17.4	36.5	30	27	20	0.20	90x110	VF2L392#F110
	5 600	16.9	35.5	25	20	20	0.20	77x165	VF2L472#E165
		18.9	39.7	25	20	20	0.20	90x126	VF2L472#F126
	6 800	18.6	39.1	20	17	20	0.20	77x188	VF2L562#E188
		20.5	43.1	20	17	20	0.20	90x150	VF2L562#F150
8 200	21.2	44.5	17	17	20	0.20	77x228	VF2L682#E228	
	22.2	46.6	17	17	20	0.20	90x167	VF2L682#F167	
10 000	24.6	51.7	14	14	20	0.20	90x190	VF2L822#F190	
12 000	26.5	55.7	12	12	20	0.20	90x230	VF2L103#F230	
	27.4	57.5	10	10	20	0.20	90x268	VF2L123#F268	
<b>600 VDC</b> Code: 600V  Surge Voltage 650 VDC	560	2.9	6.1	225	169	17	0.20	51x75	VF600V561#C075
	680	3.4	7.2	186	139	17	0.20	51x96	VF600V681#C096
	820	3.9	8.2	154	116	17	0.20	51x109	VF600V821#C109
	1 000	4.4	9.3	126	95	17	0.20	51x125	VF600V102#C125
	1 500	8.7	18.3	84	63	18	0.20	64x107	VF600V152#D107
		9.8	20.6	70	53	18	0.20	64x123	VF600V182#D123
	1 800	11.0	23.1	70	53	20	0.20	77x95	VF600V182#E095
		10.6	22.3	58	44	18	0.20	64x147	VF600V222#D147
	2 200	12.1	25.4	58	44	20	0.20	77x108	VF600V222#E108
		12.1	25.4	47	35	18	0.20	64x164	VF600V272#D164
	2 700	13.8	29.0	47	35	20	0.20	77x124	VF600V272#E124
		15.6	32.8	47	35	20	0.20	90x97	VF600V272#F097
	3 300	13.5	28.4	39	29	18	0.20	64x187	VF600V332#D187
		14.9	31.3	39	29	20	0.20	77x148	VF600V332#E148
	3 900	17.1	35.9	39	29	20	0.20	90x110	VF600V332#F110
		16.5	34.7	33	25	20	0.20	77x165	VF600V392#E165
	4 700	18.5	38.9	33	25	20	0.20	90x126	VF600V392#F126
		18.3	38.4	27	20	20	0.20	77x188	VF600V472#E188

Additional designs on request · Weitere Designs auf Anfrage



Rated VoltageCode (Surge Voltage) $V_r$ [V DC]	Capacitance $C_r$ [ $\mu$ F]	Ripple Current at 85°C/120Hz $I_r$ [A RMS]	Ripple Current at 40°C/120Hz [A RMS]	ESR (typ) at 20°C/100Hz [m $\Omega$ ]	Zmax at 20°C/10kHz [m $\Omega$ ]	ESL (typ) [nH]	Dissipation Factor at 20°C/120Hz Tan $\delta$	DxL [mm]	Product Code  # = variable value, see fixing code in the product code
<b>600 VDC</b> Code: <b>600V</b> Surge Voltage 650 VDC	<b>4 700</b>	20.2	42.4	27	20	20	0.20	90x150	VF600V472#F150
	<b>5 600</b>	20.6	43.3	23	17	20	0.20	77x228	VF600V562#E228
		21.6	45.4	23	17	20	0.20	90x167	VF600V562#F167
	<b>6 800</b>	23.4	49.1	19	14	20	0.20	90x230	VF600V682#F230
<b>650 VDC</b> Code: <b>650V</b> Surge Voltage 700 VDC	<b>820</b>	6.3	13.3	157	118	18	0.20	64x94	VF650V821#D094
	<b>1 000</b>	6.9	14.5	129	97	18	0.20	64x107	VF650V102#D107
	<b>1 200</b>	7.8	16.4	107	81	18	0.20	64x123	VF650V122#D123
		8.8	18.5	107	81	20	0.20	77x95	VF650V122#E095
	<b>1 500</b>	8.6	18.1	86	65	18	0.20	64x147	VF650V152#D147
		9.8	20.6	86	65	20	0.20	77x108	VF650V152#E108
		11.3	23.8	86	65	20	0.20	90x97	VF650V152#F097
	<b>1 800</b>	11.0	23.1	71	54	20	0.20	77x124	VF650V182#E124
		12.3	25.8	71	54	20	0.20	90x110	VF650V182#F110
	<b>2 200</b>	11.9	25.0	58	44	20	0.20	77x148	VF650V222#E148
		13.5	28.4	58	44	20	0.20	90x126	VF650V222#F126
	<b>3 300</b>	16.4	34.4	39	32	20	0.20	90x150	VF650V332#F150

\* Please contact us if load condition exceeds terminals related  $I_{r,max}$  referred on page 11

Additional designs on request · Weitere Designs auf Anfrage

## > Ripple Current Multiplier · Wechselstrommultiplikator

Frequency [Hz]	50/60	120	300	1k	$\geq 10k$
Multiplier	0.80	1.00	1.18	1.34	1.45

Ta (°C)	40	45	50	55	60	65	70	75	80	85
Multiplier 6.3-100VDC	2.7	2.6	2.4	2.3	2.2	2.0	1.7	1.4	1.2	1.0
Multiplier 160-250VDC	2.7	2.5	2.3	2.2	2.1	1.9	1.6	1.3	1.1	1.0
Multiplier 350-650VDC	2.1	2.0	1.9	1.8	1.7	1.5	1.3	1.2	1.1	1.0

Forced cooling – Wind speed [m/sec]	$v < 0.25$	$v \geq 0.25$	$v \geq 0.5$	$v \geq 1.0$	$v \geq 2.0$	$v \geq 3.0$
Multiplier	1.00	1.07	1.15	1.25	1.30	1.35



> Life Time Table · Brauchbarkeitsdauer – Tabelle

VF 6.3-100VDC	Useful life as function of ambient temperature and ripple current											
$I_r$ at 85°C	x 1.0	x 1.1	x 1.2	x 1.3	x 1.4	x 1.5	x 1.7	x 2.0	x 2.2	x 2.4	x 2.6	x 2.7
$T_a = 40^\circ\text{C}$	250	250	250	250	250	250	241	178	141	109	83	72
$T_a = 45^\circ\text{C}$	250	242	227	212	197	182	152	112	89	69	52	
$T_a = 50^\circ\text{C}$	162	153	143	134	124	115	96	71	56	43		
$T_a = 55^\circ\text{C}$	102	96	91	84	78	72	61	45	35			
$T_a = 60^\circ\text{C}$	64	61	57	53	49	46	38	28	22			
$T_a = 65^\circ\text{C}$	41	38	36	33	31	29	24	18				
$T_a = 70^\circ\text{C}$	25	24	23	21	19	18	15					
$T_a = 75^\circ\text{C}$	16	15	14	13	12							
$T_a = 80^\circ\text{C}$	10	9	9									
$T_a = 85^\circ\text{C}$	6											

khrs      Max. value limited to 250 000 hours.

VF 160-250VDC	Useful life as function of ambient temperature and ripple current												
$I_r$ at 85°C	x 1.0	x 1.1	x 1.2	x 1.3	x 1.4	x 1.5	x 1.7	x 1.9	x 2.1	x 2.3	x 2.5	x 2.7	
$T_a = 40^\circ\text{C}$	250	250	250	250	250	250	203	156	116	84	59	40	
$T_a = 45^\circ\text{C}$	250	237	218	199	180	162	128	98	73	53	37		
$T_a = 50^\circ\text{C}$	162	150	138	126	114	102	81	62	46	33			
$T_a = 55^\circ\text{C}$	102	95	87	79	72	64	51	39	29				
$T_a = 60^\circ\text{C}$	64	60	55	50	45	41	32	24	18				
$T_a = 65^\circ\text{C}$	41	38	34	31	28	25	20	15					
$T_a = 70^\circ\text{C}$	25	24	22	20	18	16							
$T_a = 75^\circ\text{C}$	16	15	13	12									
$T_a = 80^\circ\text{C}$	10	9											
$T_a = 85^\circ\text{C}$	6												

khrs      Max. value limited to 250 000 hours.

VF 350-650VDC	Useful life as function of ambient temperature and ripple current												
$I_r$ at 85°C	x 1.0	x 1.1	x 1.2	x 1.3	x 1.4	x 1.5	x 1.6	x 1.7	x 1.8	x 1.9	x 2.0	x 2.1	
$T_a = 40^\circ\text{C}$	250	250	250	246	204	166	134	106	83	64	48	36	
$T_a = 45^\circ\text{C}$	250	218	186	156	129	105	84	67	52	40	30		
$T_a = 50^\circ\text{C}$	160	138	117	98	81	66	53	42	33	25			
$T_a = 55^\circ\text{C}$	101	87	74	62	51	42	33	26	21				
$T_a = 60^\circ\text{C}$	64	55	47	39	32	26	21	17					
$T_a = 65^\circ\text{C}$	40	34	29	24	20	16							
$T_a = 70^\circ\text{C}$	25	22	18	15									
$T_a = 75^\circ\text{C}$	16	13	11										
$T_a = 80^\circ\text{C}$	10	8											
$T_a = 85^\circ\text{C}$	6												

khrs      Max. value limited to 250 000 hours.

> Life Time Graph · Brauchbarkeitsdauer – Diagramm

Useful life depending on ambient temperature  $T_a$  and ripple current operating conditions  $I_r$  versus rated ripple current at the upper category temperature  $I_{r, 85^\circ\text{C}, 120\text{Hz}}$

Brauchbarkeitsdauer in Abhängigkeit von Umgebungstemperatur  $T_a$  und Wechselstrombelastung  $I_r$  im Verhältnis zur max. Wechselstrombelastung bei oberer Kategorie-temperatur  $I_{r, 85^\circ\text{C}, 120\text{Hz}}$

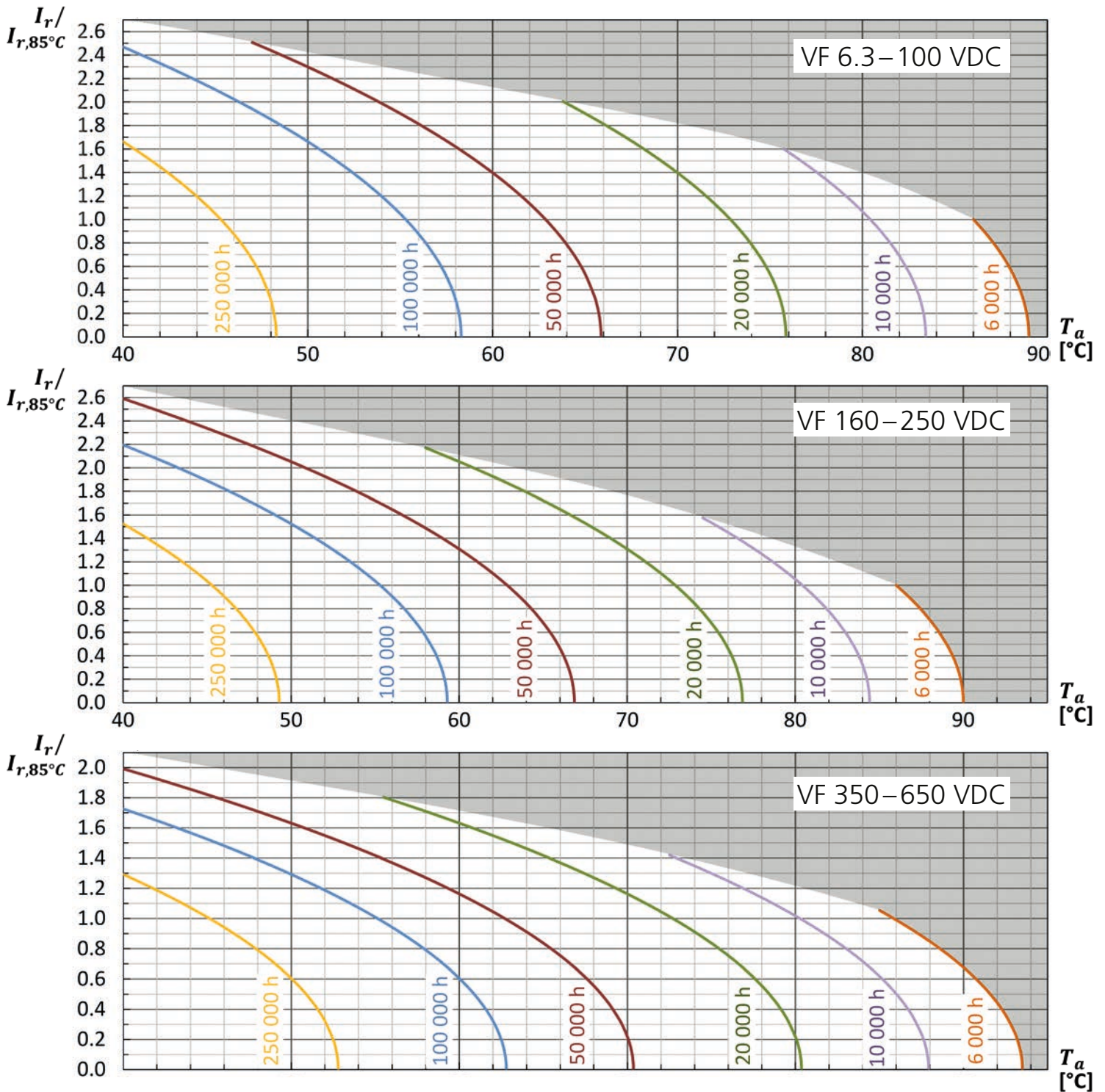

> Life Time Tests and Requirements · Anforderungen Brauchbarkeitsdauer

Life time test	Test procedure	Life time criteria
Endurance test	$T_a = 85^\circ C$ ; $V_r$ , $I_r$ applied 4000 hours	$\Delta C/C \leq 10\%$ (of initial value) $Tan\delta \leq 175\%$ (of specified value) $I_l \leq$ specified value
Useful life	$T_a = 85^\circ C$ ; $V_r$ , $I_r$ applied 6000 hours	$\Delta C/C \leq 15\%$ (of initial value) $Tan\delta < 200\%$ (of specified value) $I_l \leq$ specified value

Reference Specification: JIS C 5101-4, JIS C 5102, IEC 60384-4